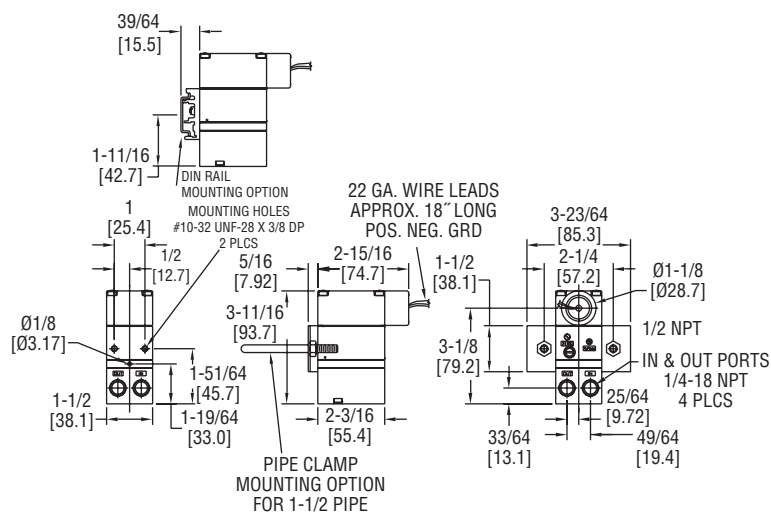




Series 2700 Current to Pressure Transducer

Specifications - Installation and Operating Instructions



The **Series 2700 Current to Pressure Transducer** is an electronic pressure regulator that converts a current signal to a proportional pneumatic output. Its compact housing, accessible ports and easy adjustments provide an ideal answer to applications that are space-constrained. The NEMA 4X enclosure enables the unit to be installed indoors or outdoors, however, the unit is not vibration resistant. It is FM and CSA approved for intrinsically safe operation. The 2700 is designed for remote or panel mounting. This economical instrument provides precision air pressure regulation to actuators, valves, positioners and other final control elements. An integral volume booster provides high flow capacity, increasing control speed in critical applications. Other features include external zero and span adjustments which are convenient for field calibration.

MODEL CHART

Model Number	Input	Output
2713-WP	4-20 mA	3-15 psig (0.2-1.0 bar)
2716-WP	4-20 mA	6-30 psig (0.4-2.1 bar)

SPECIFICATIONS

Service: Oil free, clean dry air filtered to 40 microns.

Input Signal: 4-20 mA.

Input Impedance: 2713-WP: 180 ohms; 2716-WP: 240 ohms.

Air Supply: Minimum: 5 psig (0.3 bar) above maximum output; Maximum: 100 psig (6.9 bar).

Output: 3 to 15 psig (0.2 to 1.0 bar), 6 to 30 psig (0.4 to 2.1 bar).

Linearity: $\pm 0.5\%$ of span.

Hysteresis: $< 0.5\%$ of span.

Repeatability: $< 0.5\%$ of span.

Supply Pressure Sensitivity: $< 0.1\%$ of span per 1.0 psig (0.1 bar).

Power Requirement: Loop powered.

Temperature Limits: -20 to 150°F (-29 to 66°C).

Pressure Connections: 1/4" female NPT.

Electrical Connection: 1/2" female NPT.

Air Consumption: 0.03 scfm (0.01 l/s) at midrange typical.

Output Capacity: 4.5 scfm (2.1 l/s) at 25 psig (1.7 bar) supply; 12.0 scfm (5.7 l/s) at 100 psig (6.9 bar) supply.

Enclosure: Chromate-treated aluminum with epoxy paint.

Enclosure Rating: NEMA 4X (IP65) and intrinsically safe.

Weight: 1.3 lb (0.59 kg).

Agency Approvals: CE, CSA, FM.

INSTALLATION

Pre-installation Requirements

Environment: Suitable for installation in intrinsically safe operation in hazardous locations outdoors (NEMA 4X, CSA.ENC.4 & IP65).

DANGER: All wiring must be made to all local and national codes appropriate to the area of installation.

Electrical Input: 4-20 mA DC current source.

Air Supply: Clean, dry, oil free instrument air filtered to 40 micron.

Note: Clean all pipe lines to remove dirt and scale prior to installation. Failures attributable to instrument air supply contamination are not covered by the warranty.

CAUTION: This instrument vents to atmosphere. The use of supply gas other than air can create a hazardous environment.

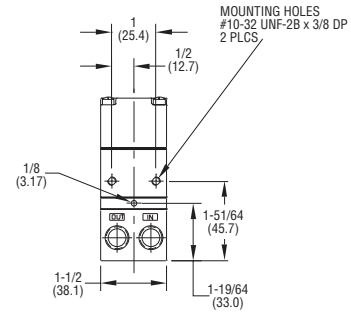
Mounting

The standard mounting kit enables panel or wall mounting of the unit. For 1-1/2" and 2" pipe mounting, use the optional kit that is Dwyer part number A-182.

To mount unit to a 1-1/2" pipe, use two 10-32 holes on the back of the unit to attach bracket to transducer. then place U-bolt around pipe and through bracket. Place nuts on U-bolt and tighten (see Figure 1).

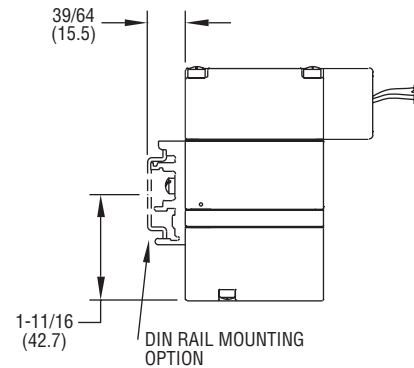
With access to the rear of a panel, attach transducer using two 10-32 screws and the two threaded mounting screws on the back of the unit. With no access to the back of the panel, attach the bracket to the transducer using the two 10-32 holes on the back of the unit and mount bracket to panel using four 10-32 screws (see Figure 2).

Due to its light weight, the Series 2700 can also be mounted in line with support provided by the supply and output piping.

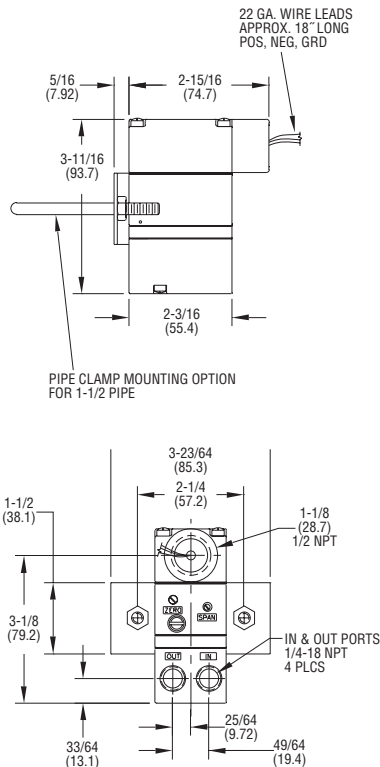


**Figure 2
Panel Mounting**

The Series 2700 can be mounted to a DIN-rail using the optional kit that is Dwyer part number A-181. This will allow the transducer to mount to DIN 50045, 50035, 50022 rails (see Figure 3).



**Figure 3
DIN Rail Mounting Kit**



**Figure 1
Pipe Mounting**

Pneumatic Connections

Clean all pipe lines to remove dirt and scale prior to installation. Supply air must be filtered to 40 microns and free of moisture and lubricants. Two (2) 1/4" NPT ports are provided for supply air connections. Either port may be used. The unused port must be plugged with the pipe plug included with the unit. Two (2) 1/4" ports are provided for pneumatic output connections. Either port may be used and one may be used for the mounting of an output gage. If no gage is installed, the unused port must be plugged with the pipe plug included with the unit.

Electrical Connections

The Series 2700 is a two wire device (does not require a separate power source), plus a safety ground. The unit requires a variable input current of 4-20 mA. The 1/2" NPT conduit connection is made using 18" pigtail wire coming from the unit. Electrical connections are made to the red (+) and black (-) leads. The green lead is furnished for case ground (see Figure 4).

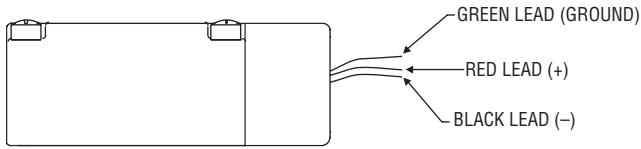


Figure 4
1/2" Conduit Connection

Factory Mutual Research Corporation (FM) Intrinsically

Safe Ratings: IS / I, II, III / 1 / CDEFG / T4 Ta = 70°C - 431-990-036; Entity; Type 4X Entity Parameters: Vmax = 30 V, Imax = 0.7 W, Ci = 0, Li = 0

Equipment Ratings:

Intrinsically safe electrical apparatus with Entity parameters for use in Class I, II, III, Division 1, Groups C, D, E, F and G in accordance with manufacturing Control Drawing No. 431-990-036, Rev. 1; nonincendive for Class I, Division 2, Groups A, B, C and D; suitable for Class II and III, Division 2, Groups F and G hazardous (Classified) indoor/outdoor Type 4X locations.

CSA Intrinsically Safe Ratings:

Ex nA, Group IIB, T4: Class I, Div 2, Groups C and D; Class II, Groups E, F and G; Class III; Encl Type 4X input rated 7-30 VDC, 125 mA max. Connected as per Dwyer installation drawing 531-990-045. Enclosure Type 4X. Maximum ambient temperature range -30°C to 70°C.

Ex ia IIB, T4; Encl Type 4X, intrinsically safe, with entity parameters: Ui = 30 VDC, li = 125 mA, Pi = 0W, Ci = 0µF, Li=0mH; when connected as per Dwyer installation drawing 531-990-045; Enclosure Type 4X. Maximum ambient temperature range -30°C to 70°C.

OPERATION

Calibration

All units are shipped from the factory calibrated, direct acting.

Note: Factory calibration is susceptible to shift due to handling during transit. Dwyer Instruments recommends that all units be calibrated prior to use.

Though the units are shipped fully calibrated it is suggested that the user check the calibration to ensure that settings and operation match the application requirements.

Note: The unit must be calibrated in the plane it is mounted in.

Direct Acting Calibration

In direct acting operation the unit is calibrated so that minimum input signal corresponds to minimum output pressure and increasing input signal results in increasing output pressure. Apply the minimum input signal of the range being used (e.g. 4 mA). Observe the output pressure. If necessary, adjust the zero screw until reaching minimum output pressure setting. Turn zero screw clockwise to increase and counter-clockwise to decrease.

Note: If unable to achieve output during calibration process, turn zero adjustment screw clockwise for up to 30 revolutions or until output pressure rises.

TROUBLESHOOTING

Problem	Look For	Solution
No or low output	Zero Adjustment Supply pressure too low	Reset zero Increase supply pressure (see specs)
Unstable/low output	Electrical connection Clogged orifice	Check connection/signal Clean orifice
Erratic Operation	Liquid/contamination in air supply	Clean air supply
Works in reverse	Pressure goes down when signal is increased	Reverse input wires
Output equals supply pressure	Improper pneumatic connections	Insure that supply is connected to "IN" port and output is connected to "OUT" port

Apply the maximum input signal of the range being used (e.g. 20 mA). Observe the output pressure. If necessary, adjust the span screw until reaching maximum output pressure setting.

Note: Turn span screw clockwise to increase and counter-clockwise to decrease.

After setting the span it will be necessary to recheck the zero. Repeat steps 1-4 until both end points are at required values.

MAINTENANCE

Note: Under normal circumstances, no maintenance should be required.

Instrument Air Filtration

Failures due to instrument supply air contamination are not covered by warranty. Use of oil and/or water saturated instrument air can cause erratic operation. Poor quality instrument air can result in unit failure. It is recommended that a filter regulator (such as Dwyer Series AFR) be placed upstream of each unit where oil and/or water laden instrument air is suspected.

If clean, dry air is not used the orifice can become blocked. To clean, first turn off supply air, then remove the screw located on the side of the unit above the "out" port. Unplug the orifice using a wire that has a smaller diameter than 0.012" (0.30 mm). Replace screw tightly into unit.

Note: If problems are not solved by troubleshooting procedures, contact an applications engineer for further assistance.

WARNING: These products are intended for use in industrial compressed-air systems only. Do not use these products where pressures and temperatures can exceed those listed under specifications.

The Series 2700 Current to Pressure Transducers are not field repairable and should be returned if repair is needed (field repair should not be attempted and may void warranty). Be sure to include a brief description of the problem plus any relevant application notes. Contact customer service to receive a return goods authorization number before shipping.

