



76-100 Series Stainless Steel Ball Valve

Threaded, 1/4" to 1" 2000 psig WOG, 1-1/4" to 2" 1500 psig WOG, 2-1/2" to 3" 1000 psig WOG. (See referenced P/T chart)
Cold Non-Shock. 150 psig Saturated Steam, Vacuum Service to 29 inches Hg.
Federal Specification: WW-V-35C, Type: II, Composition: SS, Style: 3.
MSS SP-110; Ball Valves Threaded, Socket-Welding, Solder Joint, Grooved and Flared Ends.

FEATURES

- Investment cast components
- RPTFE seats and stuffing box ring
- Mounting pad for easy actuator mounting
- Blow-out-proof stem design
- Adjustable packing gland
- Meets NACE MR-01-75
- SS lever and nut
- (-24) 1/4" to 2" Certified to API 607, 4th Edition, Class 600 burn

STANDARD MATERIAL LIST

1. Lever and grip	304 SS w/vinyl	7. Gland nut	A276-316
2. Stem packing	RPTFE	8. Stem	A276-316
3. Stem bearing	RPTFE	9. Lever nut	18-8 SS
4. Ball	A276-316	10. Body seal	PTFE
5. Seat (2)	RPTFE	11. Body	A351-CF8M
6. Retainer	A351-CF8M		

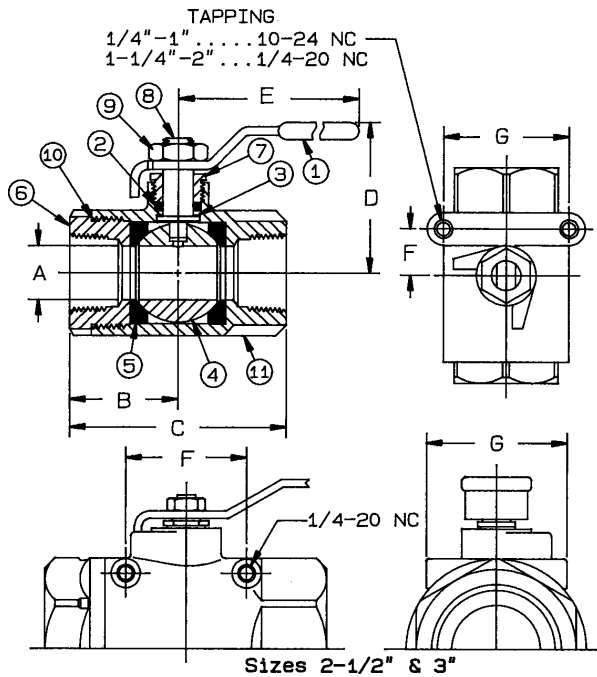

Sizes 2-1/2" & 3"

STAINLESS STEEL BALL VALVE

NUMBER	SIZE	A	B	C	D	E	F	G	Wt.
76-101-01A	1/4"	.37	1.03	2.06	1.75	3.87	.50	1.12	.58
76-102-01A	3/8"	.37	1.03	2.06	1.75	3.87	.50	1.12	.54
76-103-01A	1/2"	.50	1.12	2.25	1.81	3.87	.50	1.12	.63
76-104-01A	3/4"	.68	1.50	3.00	2.12	4.87	.87	1.37	1.27
76-105-01A	1"	.87	1.68	3.37	2.25	4.87	.87	1.37	1.63
76-106-01	1-1/4"	1.00	2.00	4.00	2.62	5.50	.93	1.50	3.06
76-107-01	1-1/2"	1.25	2.18	4.37	3.05	8.00	.93	1.50	4.04
76-108-01	2"	1.50	2.75	5.50	3.24	8.00	.93	1.50	6.05
76-109-01	2-1/2"	2.50	3.37	6.75	4.12	8.00	2.75	3.37	15.57
76-100-01	3"	2.50	3.37	6.75	4.12	8.00	2.75	3.37	16.79

OPTIONS AVAILABLE:

(SUFFIX)	OPTION	SIZES
-02-	Stem Grounded	1/4" to 3"
-03-	1-1/4" CS Stem Extension	1/4" to 3"
-04-	2-1/4" CS Stem Extension	1/4" to 3"
-07-	Steel Tee Handle	1/4" to 2"
-08-	90° Reversed Stem	1/4" to 3"
-14-	Side Vented Ball (Uni-Directional)	1/4" to 2"
-15-	Wheel Handle, Steel	1/4" to 2"
-16-	Chain Lever - Vertical	3/4" to 2"
-19-	Lock Plate	1/4" to 2"
-21-	UHMWPE Trim (Non-PTFE)	1/4" to 3"
-24-	Graphite Packing	1/4" to 3"
-27-	SS Latch-Lock Lever & Nut	1/4" to 3"
-30-	Cam-Lock and Grounded	1/4" to 2"
-32-	SS Tee Handle & Nut	1/4" to 2"
-35-	VTFE Trim	1/4" to 3"
-39-	SS Hi-Rise Locking Wheel Handle, SS Nut	1/4" to 2"
-40-	Cyl-Loc and Grounded	1/4" to 2"
-44-	Seal Welded	1/4" to 2"
-45-	Less Lever & Nut	1/4" to 3"
-46-	Latch Lock Lever - Lock in Closed Position Only	1/4" to 3"
-47-	SS Latch Lock Oval Handle	1/4" to 1"
-48-	SS Oval Handle (No Latch) & Nut	1/4" to 2"
-49-	Assembled Dry	1/4" to 3"
-50-	2-1/4" CS Locking Stem Extension	1/4" to 3"
-57-	Oxygen Cleaned	1/4" to 3"
-58-	Chain Lever - Horizontal	3/4" to 2"
-60-	Static Grounded Ball & Stem	1/4" to 3"
-64-	250# Steam Trim	1/4" to 3"
-P01-	BSPP (Parallel) Thread Connection	1/4" to 3"
-T01-	BSPT (Tapered) Thread Connection	1/4" to 3"

For Pressure/Temperature Ratings,
Refer to Page M-12, Graph No. 14
(1/4" to 1")
Refer to Page M-11, Graph No. 12
(1-1/4" to 2")
Refer to Page M-10, Graph No. 8
(2-1/2" to 3")

2000# CS P-T Rating (Graph 13)

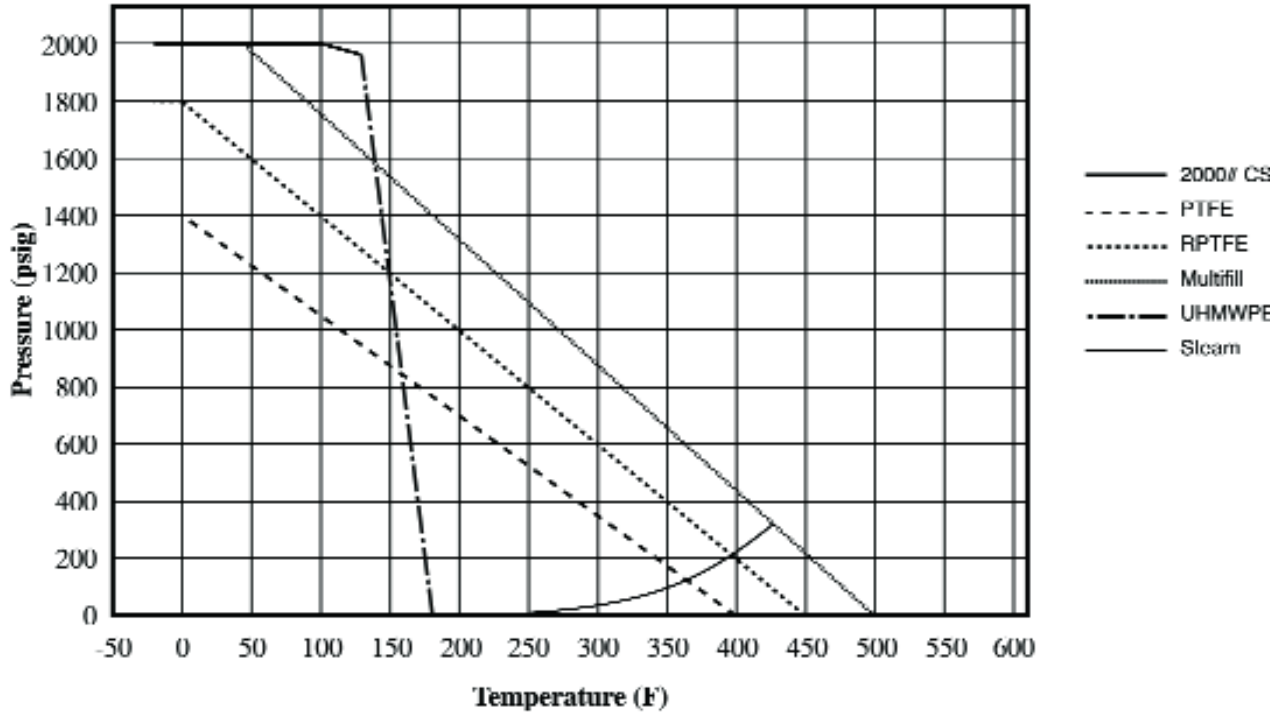

2000# SS P-T Rating (Graph 14)

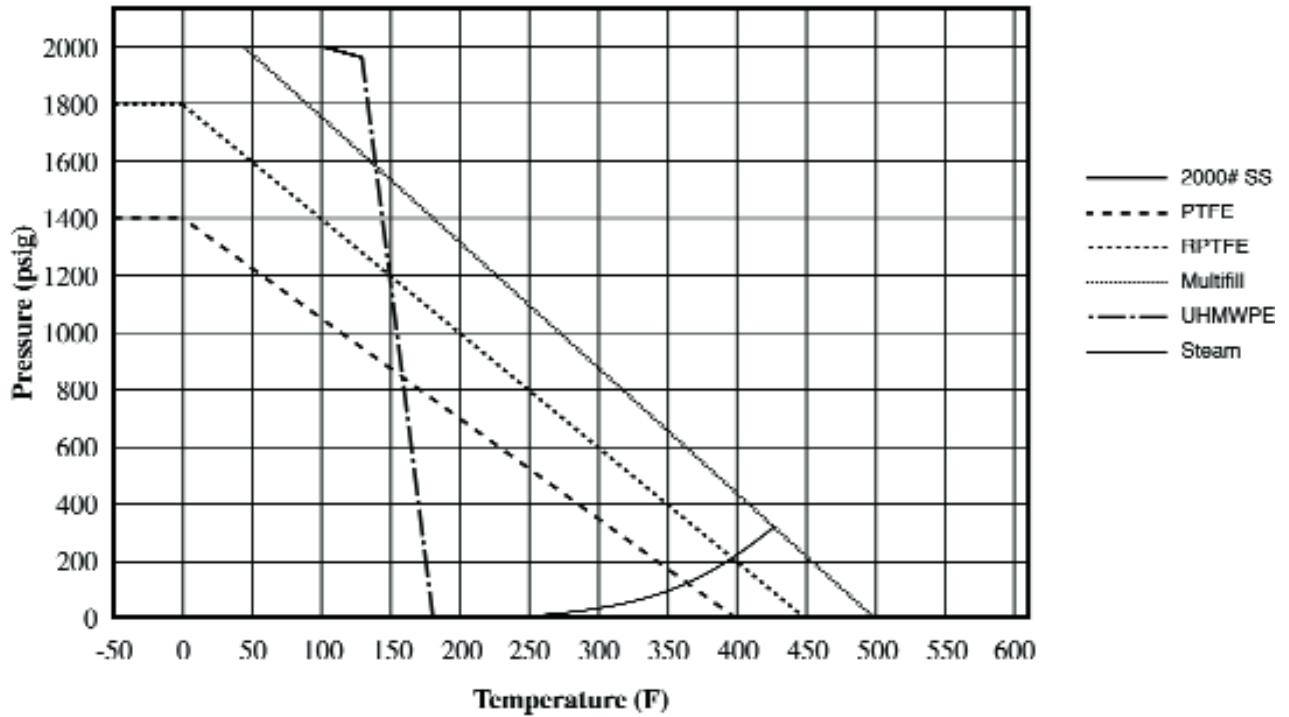

1500# CS P-T Rating (Graph 11)

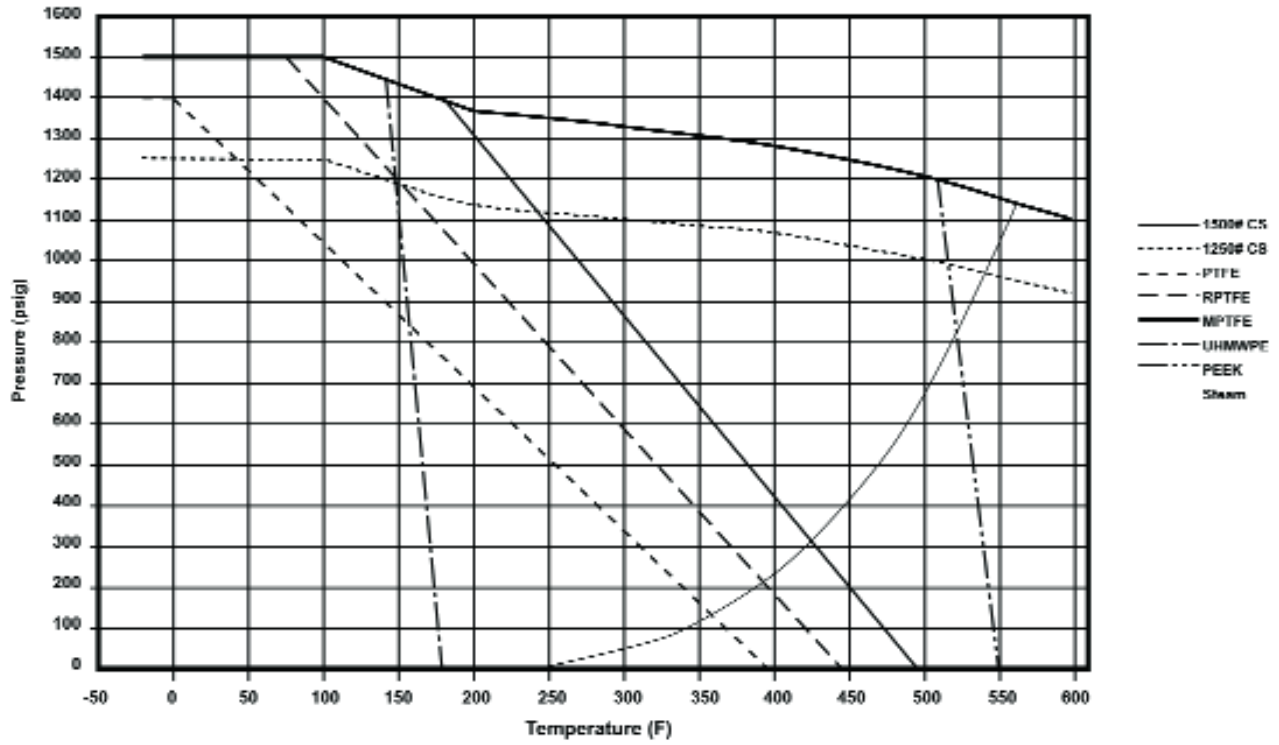

1500# SS P-T Rating (Graph 12)

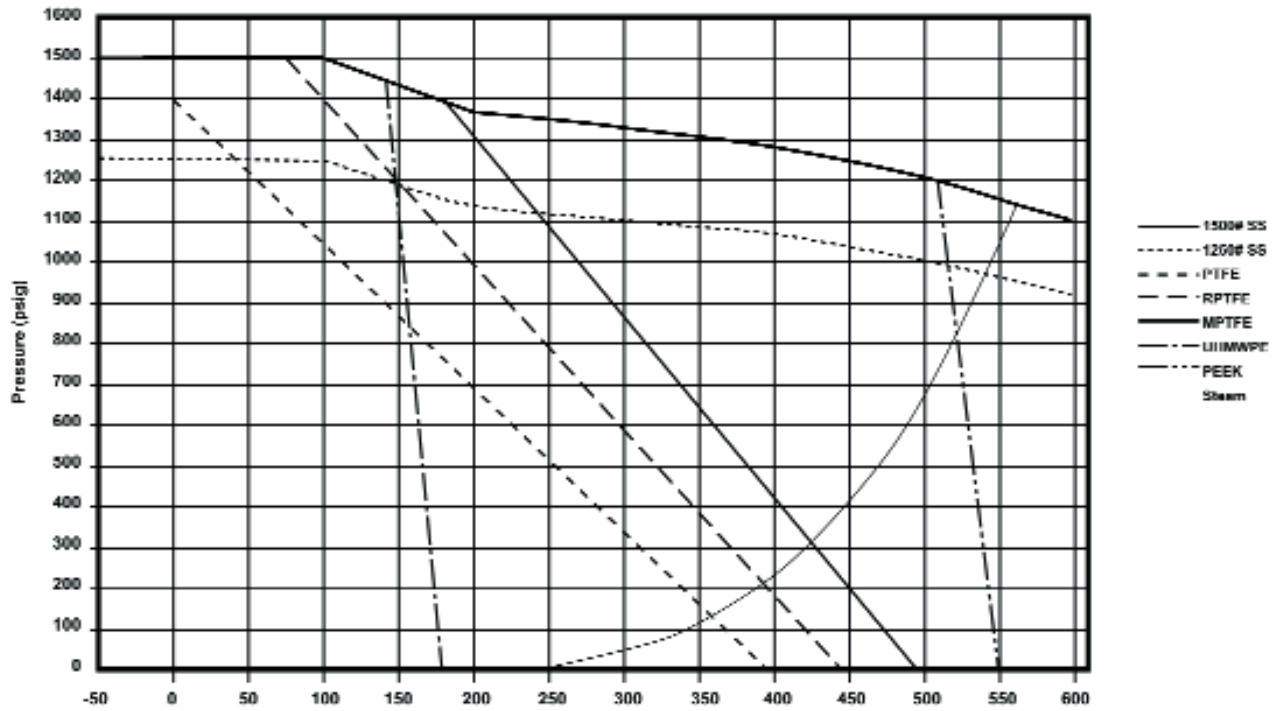

1000# CS P-T Rating (Graph 7)

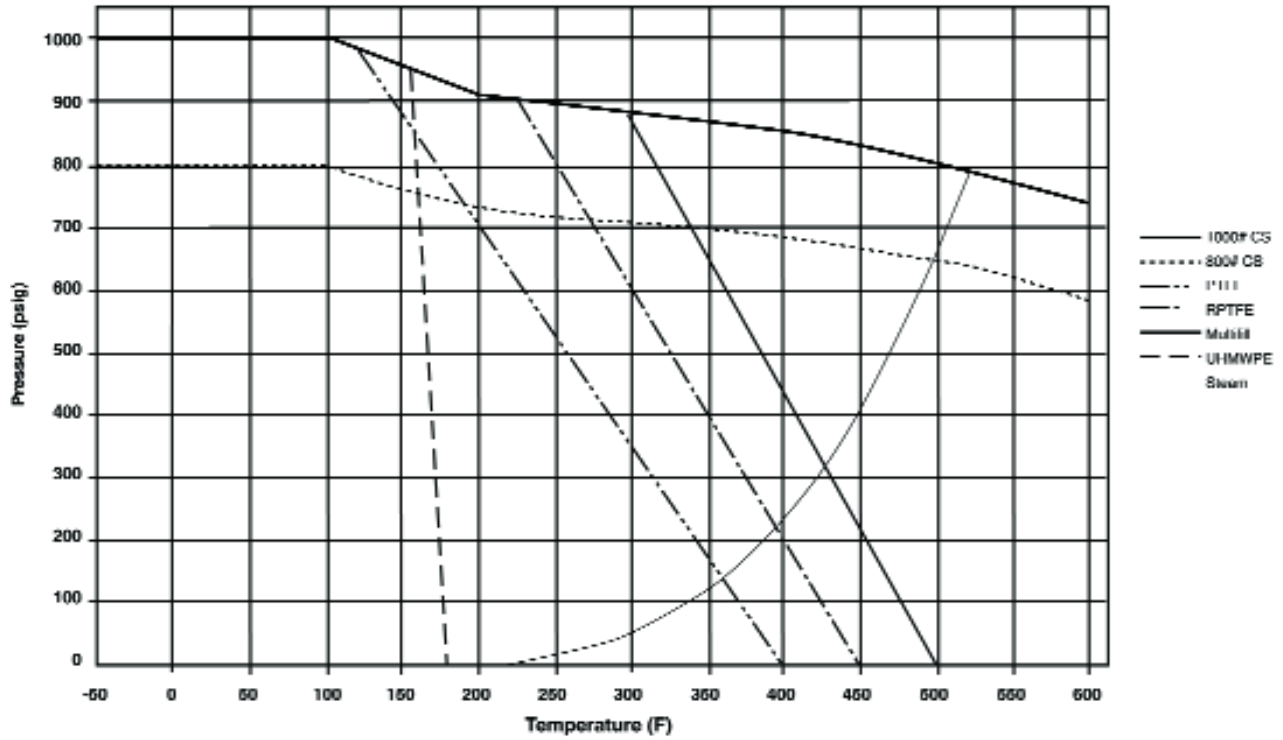

1000# SS P-T Rating (Graph 8)

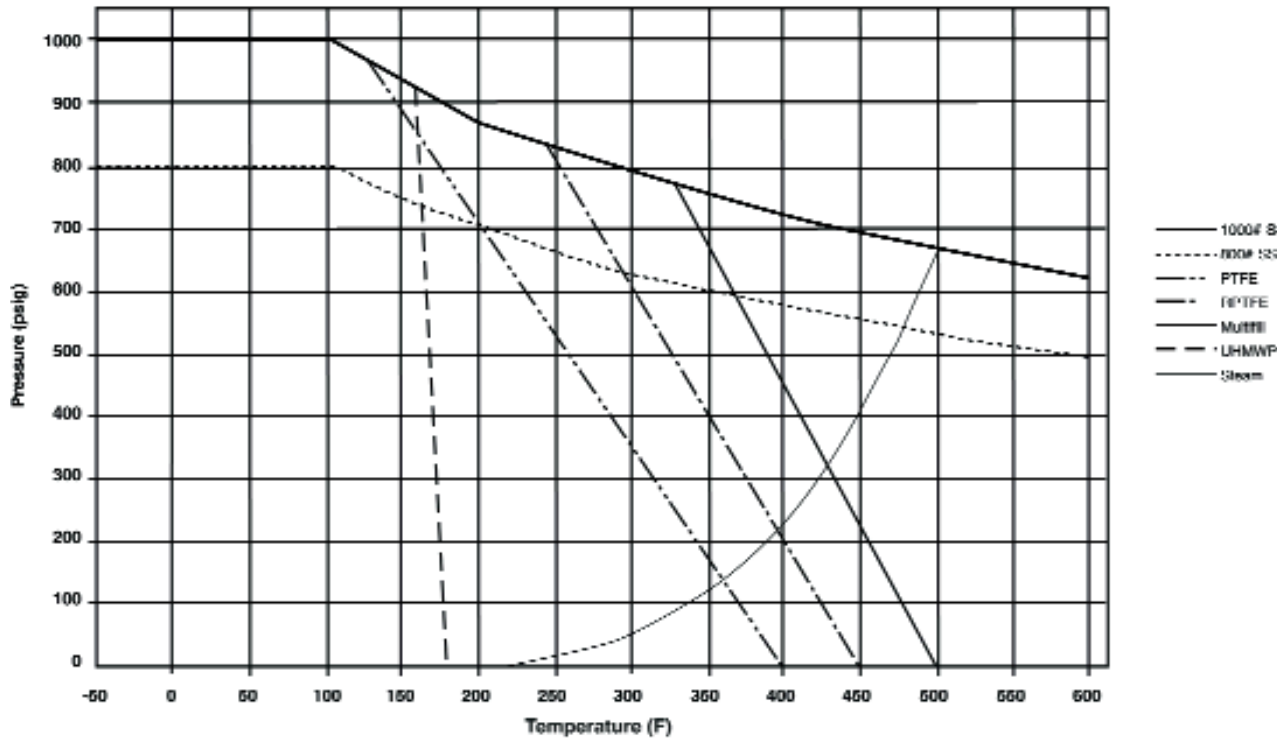

FLOW DATA

For Apollo® and Saturn® Ball Valves

The listed Cv "factors" are derived from actual flow testing, in the Apollo® Ball Valve Division, Conbraco Industries, Inc., Pageland, South Carolina. These tests were completed using standard "off the shelf" valves with no special preparation and utilizing standard schedule 40 pipe. It should be understood that these factors are for the valve only and also include the connection configuration. The flow testing is done utilizing water as a fluid media and is a direct statement of the gallons of water flowed per minute with a 1 psig pressure differential across the valve/connection unit. Line pressure is not a factor. Because the Cv is a factor, the formula can be used to estimate flow of most media for valve sizing.

Flow of Liquid

$$Q = Cv \sqrt{\frac{\Delta P}{SpGr}}$$

or $\Delta P = \frac{(Q)^2 (SpGr)}{(Cv)^2}$

Where:
 Q = flow in US gpm
 ΔP = pressure drop (psig)
 SpGr = specific gravity at flowing temperature
 Cv = valve constant

Flow of Gas

$$Q = 1360 Cv \sqrt{\frac{(\Delta P)}{(SpGr) (P_1) (T)}}$$

or $\Delta P = 5.4 \times 10^{-7} (SpGr)$

Where:
 Q = flow in SCFH
 ΔP = pressure drop (psi g)
 SpGr = specific gravity (based on air = 1.0)
 P₁ = outlet pressure-psia (psig + 14.7)
 T = (temp. °F + 460)

Cv FACTORS SERIES:

70-100, 71-100, 71AR, 73A-100,
 74-100, 76-100, 80-100
 81-100, 89-100

SIZE	1/4"	3/8"	1/2"	3/4"	1"	1-1/4"	1-1/2"	2"	2-1/2"	3"	4"
OPEN 90°	8.4	7.2	15	30	43	48	84	108	503	370	670

Cv FACTORS 76F,77,77AR,77D SERIES

SIZE	1/4"	3/8"	1/2"	3/4"	1"	1-1/4"	1-1/2"	2"	2-1/2"
OPEN 90°	8.1	15	15	51	68	125	177	389	503

Cv FACTORS 82-100/200, 83R-100/200/700,86R-100/200/700,83-500/600,86-500/600/900 SERIES

SIZE	1/4"	3/8"	1/2"	3/4"	1"	1-1/4"	1-1/2"	2"	2-1/2"	3"	4"
OPEN 90°	8.1	14	26	51	68	120	170	376	510	996	1893

Cv FACTORS 83A/83B, 86A/86B SERIES

SIZE	1/4"	3/8"	1/2"	3/4"	1"	1-1/4"	1-1/2"	2"
OPEN 90°	8.1	14	26	51	68	120	170	376