



76F-100 Series

Stainless Steel Full Port Ball Valve

Threaded, 1/4"-2" 1000 psig CWP Cold Non-Shock, 150 psig. (See referenced P/T chart)
 Saturated Steam, Vacuum Service to 29 inches Hg.
 Federal Specification: WW-V-35C, Type: II, Composition: SS, Style: 3.
 MSS SP-110; Ball Valves Threaded, Socket-Welding, Solder Joint, Grooved and Flared Ends.

FEATURES

- Investment cast components
- RPTFE seats
- MPTFE stuffing box ring
- Blow-out-proof stem design
- Adjustable packing gland
- Meets NACE MR-01-75
- SS lever and nut
- Available with SS latch lock lever (-27)

STANDARD MATERIAL LIST

1. Stem packing	MPTFE	6. Gland	A276-316 SS
2. Stem bearing	RPTFE	7. Stem	A276-316 SS
3. Ball	A276-316 SS	8. Lever nut	304 SS
4. Seat (2)	RPTFE	9. Washer	304 SS
5. Retainer	A276-316 SS (1/4" to 1") A351-CF8M (1-1/4" to 2")	10. Body	A351-CF8M
		11. Lever and grip	SS w/vinyl

OPTIONS AVAILABLE:

(SUFFIX)	OPTION	SIZES
-27-	SS Latch Lock Lever & Nut	1/4" to 2"

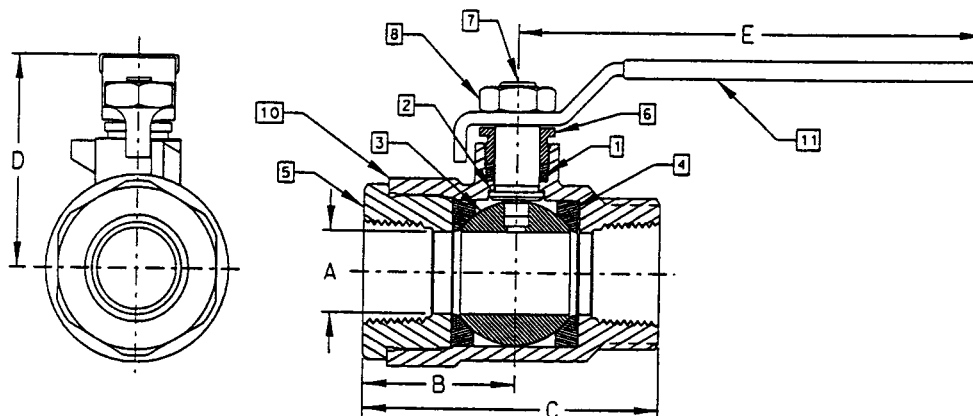

STAINLESS STEEL FULL PORT BALL VALVE

NUMBER	SIZE	A	B	C	D	E	WT.
76F-101-01	1/4"	.37	.95	1.91	1.60	3.85	.47
76F-102-01	3/8"	.37	.95	1.91	1.60	3.85	.44
76F-103-01	1/2"	.50	1.10	2.23	1.73	3.85	.55
76F-104-01	3/4"	.81	1.56	3.06	2.13	4.75	1.54
76F-105-01	1"	1.00	1.71	3.45	2.66	5.40	2.81
76F-106-01	1-1/4"	1.25	2.05	4.10	2.88	5.40	4.12
76F-107-01	1-1/2"	1.50	2.33	4.66	3.30	7.75	5.74
76F-108-01	2"	2.00	2.68	5.37	3.70	7.75	9.73

For Pressure/Temperature Ratings,
 Refer to Page M-10, Graph No. 8

1000# CS P-T Rating (Graph 7)

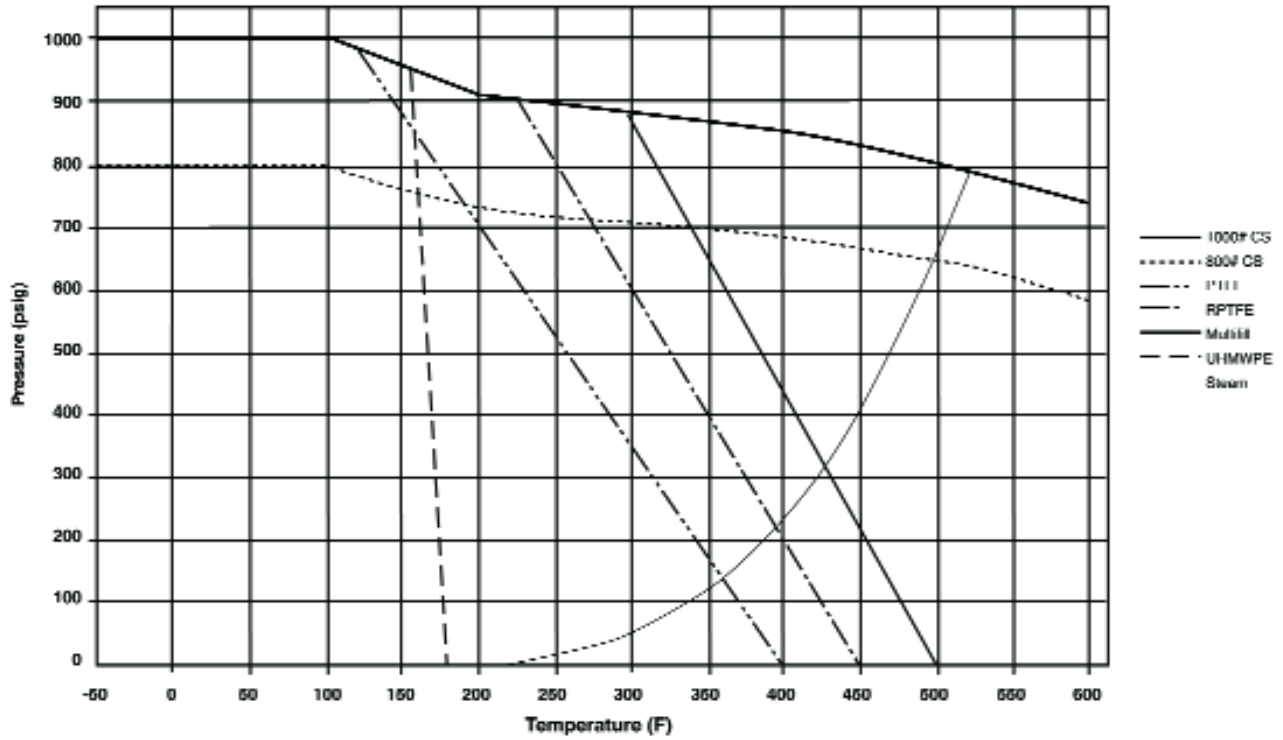

1000# SS P-T Rating (Graph 8)

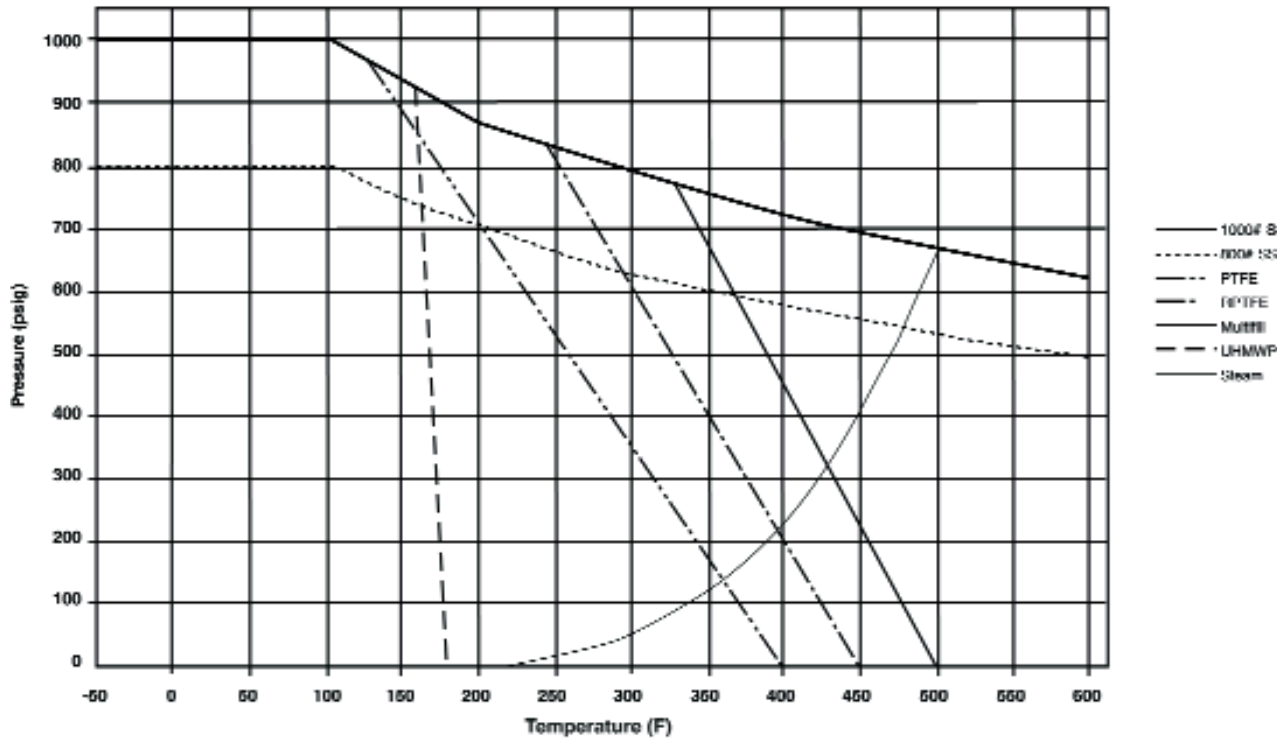

FLOW DATA

For Apollo® and Saturn® Ball Valves

The listed Cv "factors" are derived from actual flow testing, in the Apollo® Ball Valve Division, Conbraco Industries, Inc., Pageland, South Carolina. These tests were completed using standard "off the shelf" valves with no special preparation and utilizing standard schedule 40 pipe. It should be understood that these factors are for the valve only and also include the connection configuration. The flow testing is done utilizing water as a fluid media and is a direct statement of the gallons of water flowed per minute with a 1 psig pressure differential across the valve/connection unit. Line pressure is not a factor. Because the Cv is a factor, the formula can be used to estimate flow of most media for valve sizing.

Flow of Liquid

$$Q = Cv \sqrt{\frac{\Delta P}{SpGr}}$$

or $\Delta P = \frac{(Q)^2 (SpGr)}{(Cv)^2}$

Where:
 Q = flow in US gpm
 ΔP = pressure drop (psig)
 SpGr = specific gravity at flowing temperature
 Cv = valve constant

Flow of Gas

$$Q = 1360 Cv \sqrt{\frac{(\Delta P)}{(SpGr) (P_1) (T)}}$$

or $\Delta P = 5.4 \times 10^{-7} (SpGr)$

Where:
 Q = flow in SCFH
 ΔP = pressure drop (psi g)
 SpGr = specific gravity (based on air = 1.0)
 P₁ = outlet pressure-psia (psig + 14.7)
 T = (temp. °F + 460)

Cv FACTORS SERIES:

70-100, 71-100, 71AR, 73A-100,
 74-100, 76-100, 76AR, 80-100
 81-100, 89-100

SIZE	1/4"	3/8"	1/2"	3/4"	1"	1-1/4"	1-1/2"	2"	2-1/2"	3"	4"
OPEN 90°	8.4	7.2	15	30	43	48	84	108	503	370	670

Cv FACTORS 76F,77,77AR,77D SERIES

SIZE	1/4"	3/8"	1/2"	3/4"	1"	1-1/4"	1-1/2"	2"	2-1/2"
OPEN 90°	8.1	15	15	51	68	125	177	389	503

Cv FACTORS 82-100/200, 83R-100/200/700,86R-100/200/700,83-500/600,86-500/600/900 SERIES

SIZE	1/4"	3/8"	1/2"	3/4"	1"	1-1/4"	1-1/2"	2"	2-1/2"	3"	4"
OPEN 90°	8.1	14	26	51	68	120	170	376	510	996	1893

Cv FACTORS 83A/83B, 86A/86B SERIES

SIZE	1/4"	3/8"	1/2"	3/4"	1"	1-1/4"	1-1/2"	2"
OPEN 90°	8.1	14	26	51	68	120	170	376