

Series 4000 Model B 3-Piece Ball Valves with ISO Bonnet

1/2" – 2" (DN 15 – 50) Standard Bore,
1/2" – 1-1/2" (DN 15 – 40) Full Bore

Installation, Maintenance and
Operating Instructions

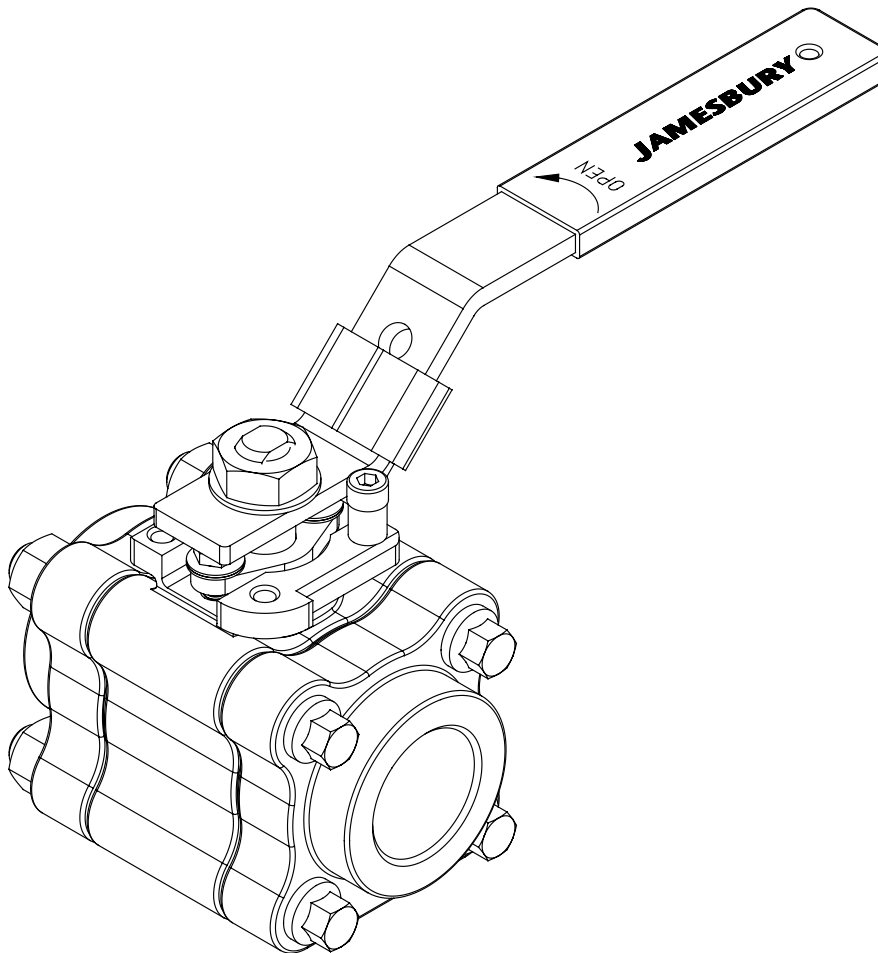

TABLE OF CONTENTS

1. GENERAL.....	3
2. INSTALLATION.....	3
3. MAINTENANCE.....	3
3.1 Disassembly.....	4
3.2 Assembly.....	4
4. REPAIR KITS/SPARE PARTS.....	6

READ THESE INSTRUCTIONS FIRST!

This instruction manual contains important information regarding the installation, operation, and troubleshooting of the Jamesbury® Series 4000 Model B 3-Piece Ball Valves with ISO Bonnet. Please read these instructions carefully and save them for future reference.

SAVE THESE INSTRUCTIONS!

Subject to change without notice.

1. GENERAL

This instruction manual contains important information regarding the installation, operation and troubleshooting for the *Jamesbury* 1/2" – 2" (DN 15 – 50) Standard Bore, 1/2" – 1-1/2" (DN 15 – 40) Full Bore Series 4000 Model B 3-Piece Ball Valves with ISO Bonnet. Please read the instructions carefully and save them for future reference.

WARNING

FOR YOUR SAFETY, TAKE THE FOLLOWING PRECAUTIONS BEFORE REMOVING THE VALVE FROM THE LINE, OR BEFORE ANY DISASSEMBLY.

1. DURING REMOVAL AND DISASSEMBLY, WEAR ANY PROTECTIVE EQUIPMENT NORMALLY REQUIRED TO PROTECT AGAINST DISCHARGE OF TRAPPED FLUID.
2. DEPRESSURIZE THE LINE AND VALVE AS FOLLOWS:
 - A. PLACE THE VALVE IN THE OPEN POSITION AND DRAIN THE LINE.
 - B. CYCLE THE VALVE TO RELIEVE RESIDUAL PRESSURE IN THE BODY CAVITY BEFORE REMOVAL FROM THE LINE.
 - C. AFTER REMOVAL, AND BEFORE ANY DISASSEMBLY, CYCLE THE VALVE AGAIN SEVERAL TIMES.
3. **SEAT AND BODY RATINGS** - THE PRACTICAL AND SAFE USE OF THIS PRODUCT IS DETERMINED BY BOTH THE SEAT AND BODY RATING. READ THE NAME TAG AND CHECK BOTH RATINGS. THIS PRODUCT IS AVAILABLE WITH A VARIETY OF SEAT MATERIALS. SOME OF THE SEAT MATERIALS HAVE PRESSURE RATINGS THAT ARE **LESS THAN** THE BODY RATINGS. ALL OF THE BODY AND SEAT RATINGS ARE **DEPENDENT ON VALVE TYPE AND SIZE, SEAT MATERIAL AND TEMPERATURE**. DO NOT EXCEED THESE RATINGS.

NOTE: OPTIONAL ROUND AND OVAL HANDLES ARE AVAILABLE FOR THESE VALVES IN PLACE OF LEVER HANDLES.

2. INSTALLATION

Screwed End Style - Use standard piping practices to install valves with threaded end caps. When tightening valve to pipe, apply wrench to end cap nearest the pipe being worked.

Weld End Style - Only valves with UHMWPE or Acetal seats must be disassembled before welding in line. A warning tag and replacement body seals are affixed to valves with these seat materials. VALVES WITH OTHER SEAT MATERIALS SHOULD BE WELDED IN-LINE FULLY ASSEMBLED.

WARNING

WELDING AND/OR GRINDING OF STAINLESS STEEL AND OTHER ALLOY STEELS CONTAINING CHROMIUM METAL MAY CAUSE THE RELEASE HEXAVALENT CHROMIUM. HEXAVALENT CHROMIUM, CHROMIUM(VI) OR CR(VI), IS KNOWN TO CAUSE CANCER. BE SURE TO USE ALL APPROPRIATE PPE WHEN WELDING METALS CONTAINING CHROMIUM. IF YOU HAVE ANY QUESTIONS CONSULT YOUR SUPERVISOR.

1. Only a qualified person should weld, as outlined in Section IX of the ASME Boiler Construction Code.
2. Cycle the valve to the fully open position.
3. Remove or protect the handle or actuator from weld splatter or arc strikes.

4. Weld by applying a recommended 1/8" (3.2 mm) max. weld bead per pass around each end cap. **CAUTION: DO NOT** heat the center section over 350°F (176.7°C). Use a temperature stick and a wet cloth wrapped around the center section to prevent overheating.
5. For welds that require multiple passes to achieve weld size, stop after each pass and carefully monitor the valve body temperature.
6. After sufficient cooling of the valve, replace the handle or actuator.

IMPORTANT: If the body seals (6) and (18) are removed for welding, **DO NOT REUSE THEM**. When reassembling the valve, put new seals back into the grooves. Body seal kits are provided in **(Table 5)**. Tighten the body bolts to the torques listed in **(Table 1)**.

TABLE 1		
Body Bolt / Hex. Nut Torque		
Valve Size Full Port Size In ()	Torque FT-LBS	Torque N-m
1/2" (1/2") DN 15 (DN 15)	10	13
3/4" DN 20	14	19
1" & 1-1/4" (3/4" & 1") DN 25 & 32 (DN 20 & 25)	26	35
1-1/2" & 2" (1-1/4" & 1-1/2") DN 40 & 50 (DN 32 & 40)	63	85

CAUTION: IF THE VALVE IS BEING DISASSEMBLED FOR WELDING, DO NOT CUT OR SCRATCH THE SEATS, SEALS AND SEALING SURFACES. DAMAGE TO THE SEALING SURFACES MAY CAUSE LEAKAGE.

After valve is in line, or before any testing, tighten compression plate hex. head cap screws according to the **MAINTENANCE** Section below.

3. MAINTENANCE

Although Metso's *Jamesbury* valves are designed to work under severe conditions, proper preventative maintenance can significantly help to prevent unplanned downtime and in real terms reduce the total cost of ownership. Metso recommends inspecting valves at least every five (5) years. The inspection and maintenance frequency depends on the actual application and process condition.

Routine maintenance consists of tightening the compression plate hex. head cap screws periodically to compensate for the wear caused by the stem turning against the stem seals. Check to make sure that the compression plate hex. head cap screws are tightened to the torque listed in **(Table 2)**. Overhaul maintenance consists of replacing seats and seals. A standard repair kit consisting of these parts may be obtained from your Metso Distributor **(see Table 4)**.

TABLE 2		
Hex. Head Cap Screw Torque		
Valve Size Full Port Size In ()	Torque IN-LBS	Torque N-m
1/2" & 3/4" (1/2") DN 15 & 20 (DN 15)	15	1.7
1" & 1-1/4" (3/4" & 1") DN 25 & 32 (DN 20 & 25)	20	2.3
1-1/2" & 2" (1-1/4" & 1-1/2") DN 40 & 50 (DN 32 & 40)	32	3.6

3.1 Disassembly

The Series 4000 ball valve is designed to be serviced in or out of the line. The following instructions are for in-line disassembly. (For bench disassembly, which may be more convenient, follow a similar sequence).

1. Comply fully with the instructions in the **WARNING** Section on page one.
2. Be sure to cycle the valve. Leave in the open position. The body center section will not swing out in the closed position.
3. Remove the handle nut (16) and handle (17).
4. Loosen all four body bolts (52). Remove three from the valve. Leave the remaining bolt in place with the hex nut (53) backed off at least 1/4" (6.4 mm).
5. For positive alignment and ease of in-line assembly, each end cap is interlocked approximately 1/16" (1.6 mm) into the body as shown in **(Figure 3)**. To overcome this feature during in-line disassembly it is necessary to separate each cap at least 1/8" (3.2 mm) from the body. Sharply rap body and caps with a block of wood or plastic mallet to break loose body seal. Spread end caps and swing the body out of the line. If pipe does not allow simple spreading, remove the remaining body bolt and rotate center section per **(Figure 1)**. This will improve access to the end cap flange for ease of spreading. Swing the valve body (1) out from between the end cap (2). Be careful not to damage the sealing surfaces "A" **(see Figure 3)** at each end of the valve.

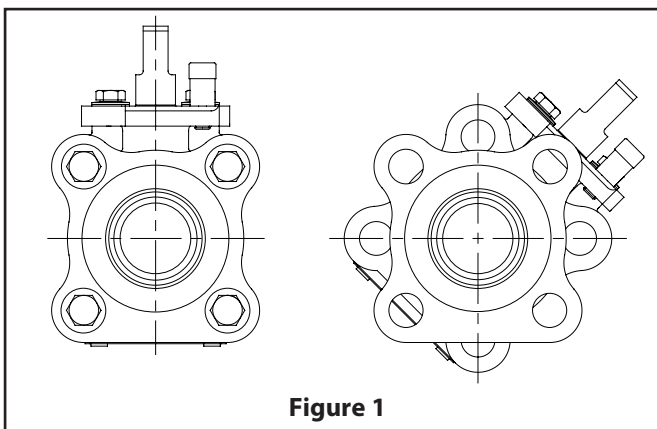

Figure 1

6. Turn the stem (4) so that the valve is fully closed. Remove the inner body seals (6) and outer body seals (18) and the seats (5). **NOTE:** On those valves with metal seats (DH seat/seal code), there is a one piece body seal (6). Body seals will be tightly compressed in their grooves. Use extreme care when prying them out. Damage such as scratches to the bottom of the groove will cause leaks. If the seats are not easily removed, gently tap the ball (3) with a piece of wood or other soft material.
7. Remove the ball (3).
8. Remove the hex. head cap screws (29), disc springs (31) and compression plate (20).
9. Press the stem (4) from the top into the valve body (1) and remove it through the end of the body.
10. Carefully pry out and discard the old stem seal (8) being careful not to damage the stem seal bore in the body. On Fire-Tite® valves, carefully pry out the stem bearings (13) and the secondary stem seal (7), being careful not to damage the bearing surfaces. **NOTE:** On non Fire-Tite valves there is only one lower stem bearing (24). Also, valves with graphite stem seals (8) have an additional upper stem bearing (10) and an anti-extrusion ring (55).

3.2 Assembly

The following instructions are for in-line assembly. For bench assembly, which may be more convenient, follow a similar sequence by holding the valve in a vise by one end cap. Use care not to cut or scratch the seats, seals or sealing surface.

1. With the valve swung to the out-of-line position, insert from the inside of the body a stem bearing (13), a secondary stem seal (7), then another stem bearing (13) into the stem bore. For non-Fire-Tite valves use one stem bearing (24). See **(Figure 3)** and parts list **(Figure 4)**.
2. Insert the stem (4) horizontally into the body bore (threaded end first). The blade at the ball end of the stem must be vertical **(see Figure 2)**. Guide the stem into the stem bore being careful not to scratch the bearings.

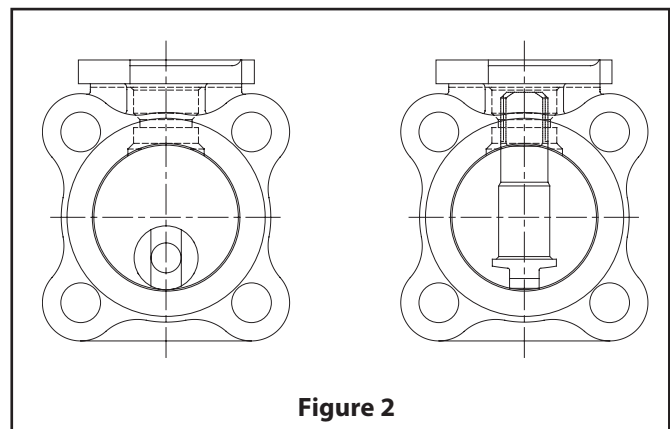

Figure 2

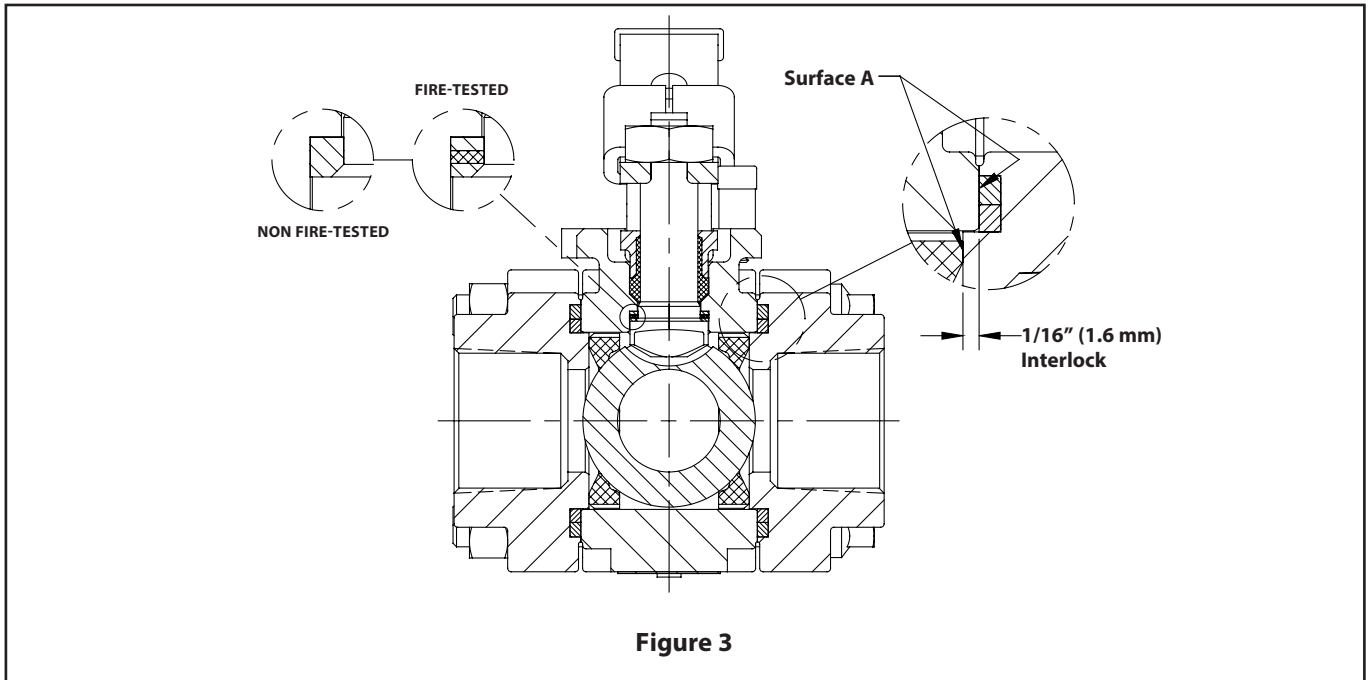

Figure 3

3. Holding the stem in place from the bottom, install the stem seal (8) and the compression plate (20). For valves with graphite stem seals (8), install upper stem bearing (10) and anti-extrusion ring (55) prior to installing the stem seal (8).
4. Place the disc springs (31) on top of the compression plate over the bolt holes and insert the hex. head cap screws (29) and bring them down hand tight with the disc springs. **NOTE:** See (Figure 4) for proper disc spring orientation.
5. While pressing the stem upward from inside the body, torque the hex head cap screws (29) applying the torque shown in (Table 2). Apply torque evenly alternating between the two hex head cap screws so that compression plate will be parallel with the valve body bonnet.
6. Align the stem blade with the ball slot. Insert the ball (3) and then rotate the stem (4) so that the ball is in the closed position.
7. Working at either end of the body (1), place a seat (5) into the body. Fit it snugly against the closed ball. **NOTE:** The sealing surface of the seat is toward the ball (see Figure 4).
8. Place an inner body seal (6) and an outer body seal (18) into the machined sealing groove of the body cap (2) (see Figure 3). **NOTE:** On those valves with metal seats (DH seat/seal code), there is a one piece body seal (6). Be certain that the groove and seal are clean.
9. Repeat steps 7 and 8 for assembly at the opposite end.
10. Turn the stem so that the ball is in the full open position.
11. Swing the entire body assembly back into the properly aligned and interlock position between the body caps, being careful not to scratch the body seals. Body caps may have to be spread slightly to accept the body.
12. Close the valve.
13. Bolt the valve together with lubricated body bolts (52) and hex. nuts (53). Tighten these bolts evenly and alternately. (See Table 1 for the torques.)
14. Attach the handle (17) and secure it with the handle nut (16) applying the torque shown in (Table 3).

TABLE 3		
Handle Nut Torque		
Valve Size Full Port Size In ()	Torque FT•LBS	Torque N•m
1/2" & 3/4" (1/2") DN 15 & 20 (DN 15)	9	12
1" & 1-1/4" (3/4" & 1") DN 25 & 32 (DN 20 & 25)	23	31
1-1/2" & 2" (1-1/4" & 1-1/2") DN 40 & 50 (DN 32 & 40)"	33	45

4. REPAIR KITS/SPARE PARTS

We recommend that valves be directed to our service centers for maintenance. The service centers are equipped to provide rapid turn-around at a reasonable cost and offer new valve warranty with all reconditioned valves.

NOTE: When sending goods to the service center for repair, do not disassemble them. Clean the valve carefully and flush the valve internals. Include the material safety datasheet(s) (MSDS) for all media flowing through the valve. Valves sent to the service center without MSDS datasheet(s) will not be accepted.

For further information on spare parts and service or assistance visit our web-site at www.metso.com/valves.

NOTE: When ordering spare parts, always include the following information:

- Valve catalog code from identification plate,
- If the valve is serialized – the serial number (from identification plate)
- From **Figure 4**, the ballooned part number, part name and quantity required

NOTE: Repair kits include two seats (5), one stem seal (8), two stem bearings (13), one secondary stem seal (7), one stem bearing (24), two inner body seals (6) and two outer body seals (18). Consult the factory for replacement parts of valves with seat materials not listed or for special services.

Repair Kits	Valve Size – Full Port Size Shown in ()					
Valve Size	1/2" (1/2") DN 15 (DN 15)	3/4" DN 20	1" (3/4") DN 25 (DN 20)	1-1/4" (1") DN 32 (DN 25)	1-1/2" (1-1/4") DN 40 (DN 32)	2" (1-1/2") DN 50 (DN 40)
PTFE Seats	RKN-354-TT	RKN-355-TT	RKN-356-TT	RKN-357-TT	RKN-358-TT	RKN-359-TT
Acetal Seats	RKN-354-RT	RKN-355-RT	RKN-356-RT	RKN-357-RT	RKN-358-RT	RKN-359-RT
Peek® Seats	RKN-354-LG	RKN-355-LG	RKN-356-LG	RKN-357-LG	RKN-358-LG	RKN-359-LG
Metal Seats	RKN-354-DH	RKN-355-DH	RKN-356-DH	RKN-357-DH	RKN-358-DH	RKN-359-DH
Xtreme® Seats	RKN-354-XT	RKN-355-XT	RKN-356-XT	RKN-357-XT	RKN-358-XT	RKN-359-XT
PFA Seats	RKN-354-BT	RKN-355-BT	RKN-356-BT	RKN-357-BT	RKN-358-BT	RKN-359-BT

Body Seal Kits	Valve Size – Full Port Size Shown in ()					
Valve Size	1/2" (1/2") DN 15 (DN 15)	3/4" DN 20	1" (3/4") DN 25 (DN 20)"	1-1/4" (1") DN 32 (DN 25)	1-1/2" (1-1/4") DN 40 (DN 32)	2" (1-1/2") DN 50 (DN 40)
Standard – TFM + Graphite	RKN-348-TT	RKN-349-TT	RKN-350-TT	RKN-351-TT	RKN-352-TT	RKN-353-TT
Spiral Wnd – 316SS + Graphite	RKN-348-DH	RKN-349-DH	RKN-350-DH	RKN-351-DH	RKN-352-DH	RKN-353-DH
UHMWPE + Graphite	RKN-348-UU	RKN-349-UU	RKN-350-UU	RKN-351-UU	RKN-352-UU	RKN-353-UU

Acetal is a registered trademark of Dupont Co.

EXPLODED VIEW AND PARTS

PARTS LIST		
ITEM	PART NAME	QTY
1	Body	1
2	Body Cap	2
3	Ball	1
4	Stem	1
5	Seat	2
6	Inner Body Seal	2
7*	Secondary Stem Seal	1
8	Stem Seal	1
10†	Stem Bearing	1
13*	Stem Bearing	2
16	Handle Nut	1
17	Handle	1
18	Outer Body Seal	2
19	Shakeproof Washer	1
20	Compression Plate	1
22**	Identification Tag	1
23**	Pop Rivet	2
24***	Stem Bearing Non-Fire-Tite	1
25	Socket Head Cap Screw	1
26	Spacer	1
29	Hex. Head Cap Screw	2
31	Disc Spring	4
52	Body Bolt	4
53	Hex Nut	4
54****	Weld End Tag	1
55†	Anti-Extrusion Ring	1

* Fire-Tite Valves Only
 ** ANSI Valves Only
 *** Non-Fire-Tite Valves Only
 **** Socket Weld and Butt Weld Valves Only
 † Used for Graphite Upper Stem Seals Only

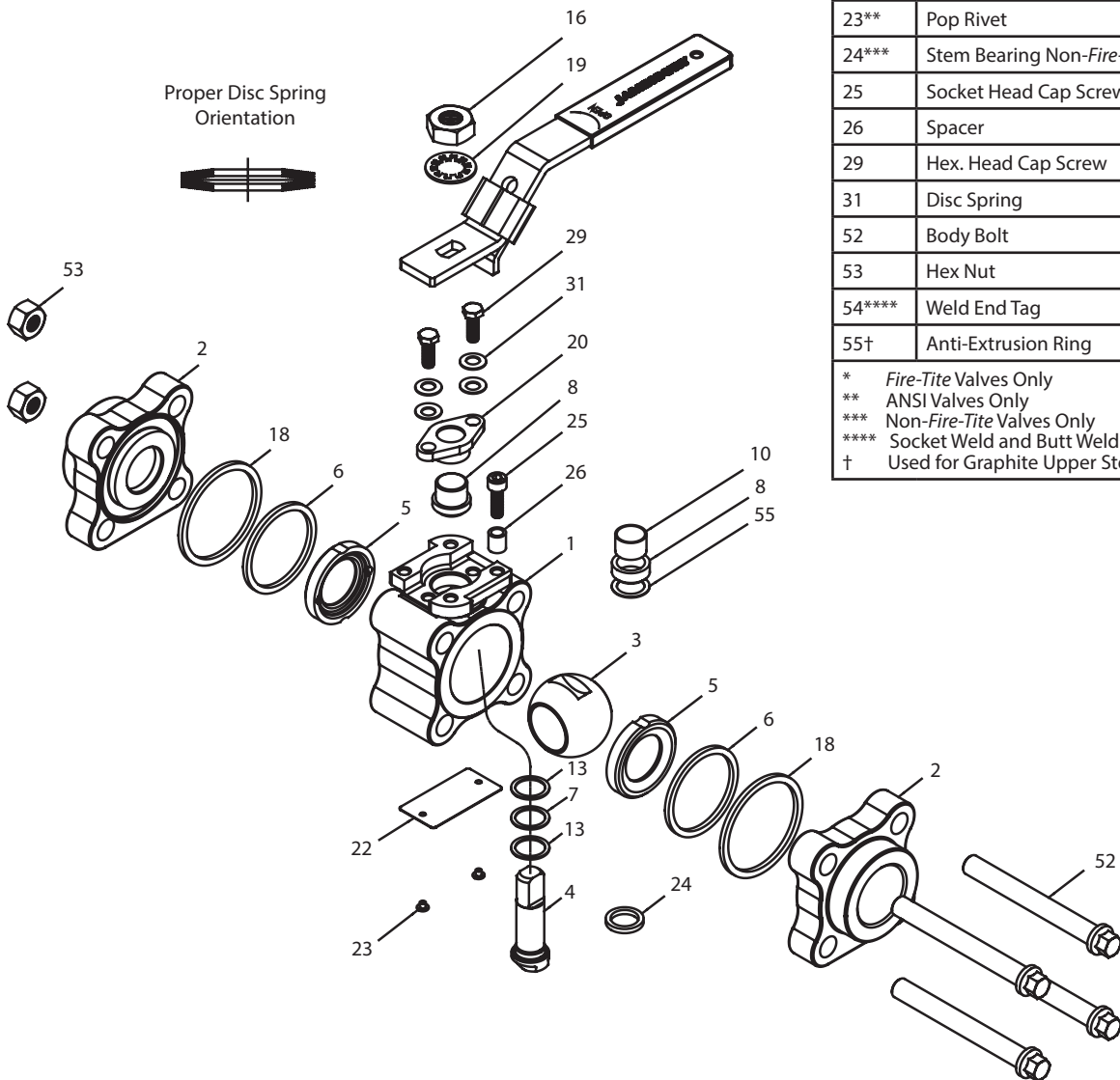

Figure 4

Subject to change without prior notice.

Metso Flow Control Inc.

Europe, Vanha Porvoontie 229, P.O. Box 304, FI-01301 Vantaa, Finland. Tel. +358 20 483 150. Fax +358 20 483 151

North America, 44 Bowditch Drive, P.O. Box 8044, Shrewsbury, M A 01545, USA. Tel. +1 508 852 0200. Fax +1 508 852 8172

South America, Av. Independência, 2500-Iporanga, 18087-101, Sorocaba-São Paulo, Brazil. Tel. +55 15 2102 9700. Fax +55 15 2102 9748

Asia Pacific, 238B Thomson Road, #17-01 Novena Square Tower B, Singapore 307685. Tel. +65 6511 1011. Fax +65 6250 0830

China, 11/F, China Youth Plaza, No.19 North Rd of East 3rd Ring Rd, Chaoyang District, Beijing 100020, China. Tel. +86 10 6566 6600. Fax +86 10 6566 2583

Middle East, Roundabout 8, Unit AB-07, P.O. Box 17175, Jebel Ali Freezone, Dubai, United Arab Emirates. Tel. +971 4 883 6974. Fax +971 4 883 6836

www.metso.com/valves

