

Class 150 Bronze Gate Valves

Fig.
B-122

Rising Stem • Solid Wedge Disc

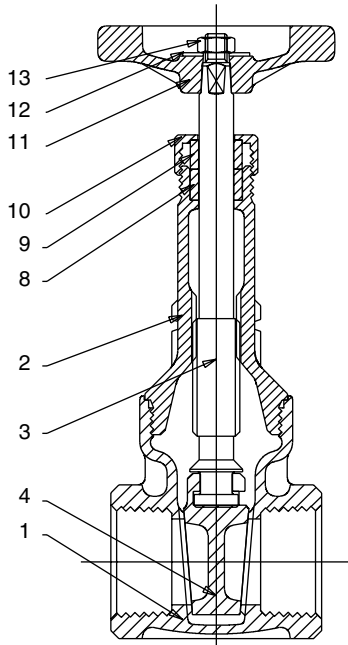

Materials of Construction

NO.	DESCRIPTION	MATERIAL	ASTM SPEC.	
1	Body		Bronze	B-62 C83600
2	Bonnet		Bronze	B-62 C83600
3	Stem	(1/4" - 2")	Bronze	B-62 C83600
		(2 1/2" & 3")	Cu-Si Bronze	B-371 C69400
4	Disc		Bronze	B-62 C83600
8	Packing		Asbestos Free	
9	Packing Gland	Brass	B-16 C36000	
10	Packing Nut	(1/4" - 2")	Brass	B-16 C36000
		(2 1/2" & 3")	Bronze	B-584 C84400
11	Handwheel		Malleable Iron	A-197 F22000
12	ID Plate		Aluminum	
13	Handwheel Nut	Brass	B-16 C36000	

Industry Standards

Complies with MSS-SP-80 Type 2

See page 6 for Pressure Temperature Ratings

Dimensions and Weights

Inches (millimeters) - Pounds (kilograms)

B-122, Threaded Bonnet, Threaded Ends

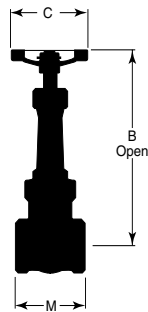

VALVE SIZE	DIMENSIONS			WT
	B	C	M	
1/4	4.96	2.25	1.81	.7
	(126)	(57)	(46)	(.32)
3/8	4.96	2.25	1.81	.7
	(126)	(57)	(46)	(.32)
1/2	5.07	2.75	1.98	1.0
	(129)	(70)	(51)	(.48)
3/4	6.25	2.75	2.14	1.6
	(159)	(70)	(55)	(.72)
1	7.44	2.75	2.46	2.4
	(189)	(70)	(63)	(1.10)
1 1/4	8.62	3.25	2.77	3.3
	(219)	(83)	(71)	(1.50)
1 1/2	9.68	4.00	2.85	4.9
	(246)	(102)	(73)	(2.25)
2	11.85	4.00	3.25	7.0
	(301)	(102)	(83)	(3.20)
2 1/2	14.53	4.75	4.25	12.8
	(369)	(121)	(108)	(5.80)
3	16.39	5.50	4.59	18.8
	(416)	(140)	(117)	(8.52)