

**API 607 - 4th Edition  
CERTIFIED**

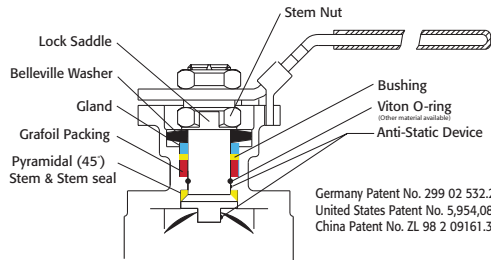

Triac 90 Series Flanged Ball Valves feature a split body design. The high quality investment castings feature a fully machined bore. The superior live-loaded packing system is accomplished with Belleville washers, "V" ring packing and a unique primary pyramidal stem seal. This advanced sealing system provides for protection against stem leaks experienced by ordinary ball valves.



Reinforced RTFE seats are standard, but various options are available for seat materials. The 50/50 seat option is excellent for services that call for higher temperatures and more difficult applications including steam. Call us for details.

VALVE SIZE	VALVE Cv
1/2"	15
3/4"	45
1"	85
1-1/2"	275
2"	460
2-1/2"	700
3"	1100
4"	2200

## Easy to Automate!

See automated data sheets for pre-sized assemblies



Pneumatic



Electric

**TRIAQ**  
CONTROLS

# Series F90

**FIRESAFE**

## Split Body Flanged Ball Valve

Sizes 1/2" - 4"

Available in 316SS or WCB

ANSI Class 150# Flanged

Full port design

Superior live-loaded packing system

ISO5211 actuator mounting pad

Anti-static device

Each valve traceable\*\*

### STANDARDS

Design	ANSI B16.34
Face to Face	ANSI B16.10
Flange Dimensions	ANSI B16.5
Pipeline Valve	API 6D
Pressure Testing	API 598
Fire Testing	API 607 4th Edition, BS 5351
Mounting Pad	ISO 5211
Marking System for Valves	MSS SP-25
Material Certification	EN 10204
Quality Assurance	ISO 9001

### HOW TO ORDER MANUAL VALVES

SAMPLE PART #

**F90C-F1-0300-XXX**

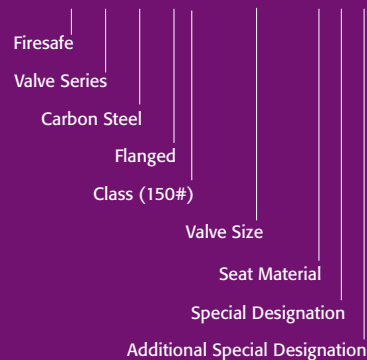

See part number matrix for itemized options

\*\*MTRs available - call for details



**SERIES F90 Split Body Flanged Ball Valve**

**Firesafe**

**A-T Controls, Inc.**

Triac Division  
11363 Deerfield Rd.  
Cincinnati, Ohio 45242

PHONE(513) 247-5465  
FAX (513) 247-5462  
e-mail: sales@a-tcontrols.com  
www.a-tcontrols.com

# Series F90

## High Performance, Full Port Split Body Flanged Ball Valve Series F90 (ANSI Class 150#)

API 607 - 4th Edition  
CERTIFIED

"Firesafe"

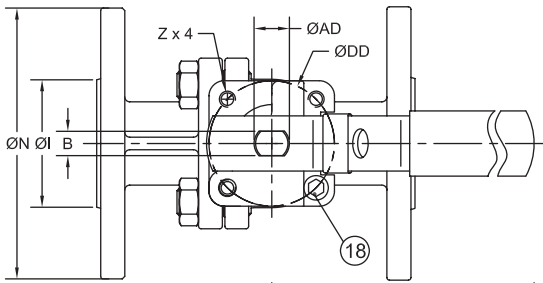

Pressure vs. Temperature Chart

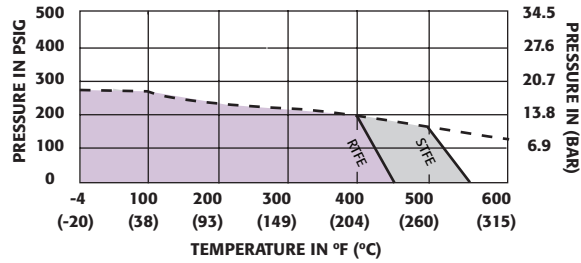

VALVE OPERATING TORQUES	
1/2"	92
3/4"	115
1"	150
1-1/2"	320
2"	415
2-1/2"	675
3"	1000
4"	1800

NOTE: RTFE Seats.  
Consult factory when using other seat material.

NOTE: Dotted line shows the rating for valve body. Solid line shows the rating for valve seat. Both ratings need to be consulted when determining the limitation of the valve for specific application.  
Consult factory for other seat material.

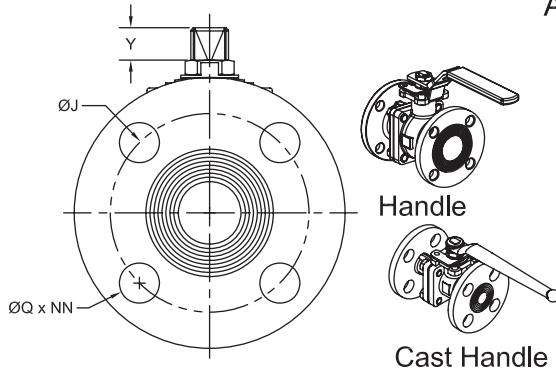
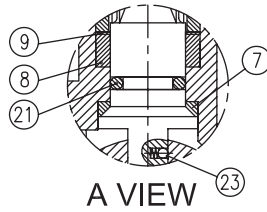
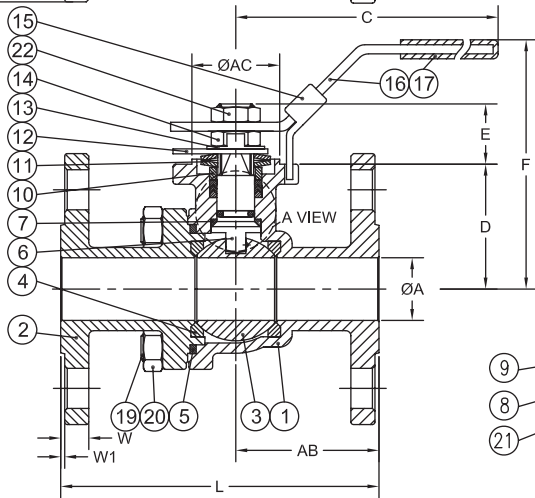

### MATERIALS LIST

NO.	PART NAME	QTY.	MATERIAL	
			Stainless Steel	Carbon Steel
1	Body	1	CF8M	WCB
2	End Cap	1	CF8M	WCB
3	Ball	1	SS316	SS316
4	Seat	2	RTFE	RTFE
5	Joint Gasket	1	Graphite	Graphite
6	Stem	1	SS316	SS316
7	Stem Seal	1	RTFE	RTFE
8	Gland Packing	&	Graphite	Graphite
9	Gland Packing	1	RTFE	RTFE
10	Gland Bush	1	SS304	SS304
11	Belleville Washer	2	SS301	SS301
12	Locking Plate	1	SS304	SS304
13	Stop Washer	1	SS304	SS304
14	Stem Nut	2	SS304	SS304
15	Locking Device	1	SS304	SS304
16	Handle	1	SS304	SS304
17	Handle Sleeve	1	Vinyl	Vinyl
18	Stop Pin	1	SS304	SS304
19	Bolt	*	SS304	SS304
20	Nut	*	SS304	SS304
21	O-Ring	1	Viton®	Viton®
22	Handle Nut	1	SS304	SS304
23	Anti-Static Device	@	SS304	SS304

\* For 1/2" - 1", Qty.=2  
 \* For 1-1/2" - 4", Qty.=3  
 \* For 1/2" - 2", 4 pcs. of studs and nuts  
 \* For 2-1/2" - 4", 8 pcs. of studs and nuts  
 @For 1/2", 1 pc., 3/4" - 4", 2 pcs.

### DIMENSIONS (IN) INVESTMENT CAST BODY

SIZE	A	B	C	D	E	F	I	J	L	N	Q	W	W1	Y	Z	AB	AC	AD	DD	NN	(LBS)	ISO 5211
1/2"	0.59	0.315	6.69	1.34	0.92	3.15	1.47	2.38	4.26	3.50	0.63	0.44	0.06	0.36	M5	1.82	1.17	0.43	1.654	4	3.7	F04
3/4"	0.79	0.315	6.69	1.65	0.94	3.43	1.82	2.75	4.62	3.88	0.63	0.44	0.06	0.40	M5	2.17	1.17	0.43	1.654	4	4.6	F04
1"	0.98	0.382	8.05	1.95	0.94	3.85	2.08	3.13	5.00	4.26	0.63	0.44	0.06	0.32	M6	2.20	1.37	0.56	1.969	4	3.1	F05
1-1/2"	1.50	0.472	10.28	3.08	1.37	6.02	2.88	3.88	6.50	5.00	0.63	0.56	0.06	0.58	M8	2.81	2.17	0.75	2.756	4	13.6	F07
2"	1.97	0.472	10.28	3.40	1.37	6.38	3.62	4.75	7.02	6.00	0.75	0.63	0.06	0.58	M8	3.38	2.17	0.75	2.756	4	19.2	F07
2-1/2"	2.56	0.472	10.28	3.83	1.37	6.81	4.12	5.50	7.49	7.00	0.75	0.69	0.06	0.58	M8	3.02	2.17	0.75	2.756	4	30.0	F07
3"	3.15	0.591	13.94	4.23	1.81	6.95	5.00	6.00	8.01	7.50	0.75	0.75	0.06	0.93	M10	4.01	2.76	0.94	4.016	4	41.0	F10
4"	3.94	0.591	13.94	4.82	1.79	7.52	6.19	7.50	9.04	9.00	0.75	0.94	0.06	0.93	M10	4.06	2.76	0.94	4.016	8	65.0	F10

Viton® is a registered trademark of E.I. DuPont de Nemours.  
 A-T Controls reserves the right to change product designs and technical/dimensional specifications without notice.

0308-F90M



A-T Controls, Inc.

Triac Division  
 11363 Deerfield Rd.  
 Cincinnati, Ohio 45242

PHONE (513) 247-5465  
 FAX (513) 247-5462  
 e-mail: sales@a-tcontrols.com  
 www.a-tcontrols.com