



A-T Controls, Inc.

# M Series Floating Metal Seat Ball Valve



# M Series

## Floating Metal Seat Ball Valve

### Full Bore Two-piece Flanged Ends ANSI 150/300/600LB

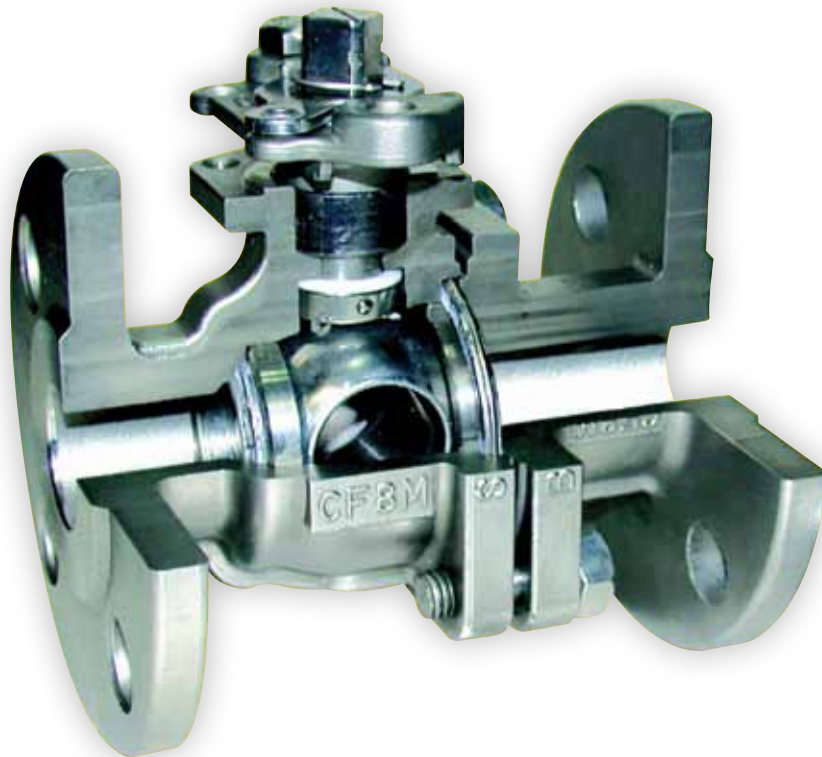

The A-T Controls M Series metal seat ball valve is designed for use in severe services such as high temperature and abrasive fluids. It is used in the areas of oil and gas, petroleum, chemicals and petrochemicals, power generation, pulp and paper, and mining.

### Product Features

- Precise CNC machining enables the ball and seats to seal tightly, offering superior shutoff.
- Spring live-loaded seats ensure tight seal, even at low temperature and pressure.
- Fire safe design conforms to API 607 4th edition.
- Select material for different service applications.
- Hard face treatment on ball and seats for longer life cycle in severe environments.
- Uni-directional shutoff is standard with bi-directional shutoff available as an option.



HVOF Thermal Spray

## Applications

- Abrasive Fluids
- High Temperature Process
- Steam

## Design and Structures

Gland Packing: Flexible Graphite

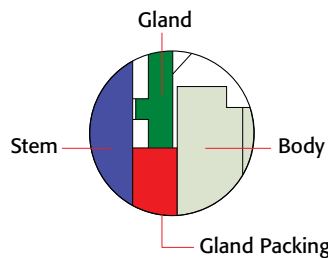

### Gland Packing Area

Fire safe graphite gland packing to ensure safety under fire conditions

### Seat Spring

Inconel X750



### Seat

Stainless Steel  
Stellite Welded  
TC Coated  
CC Coated

### Stem

17-4PH/XM-19/Duplex 2205/Inconel 718



### Stem Area

Blow-out proof design



### Ball

Stainless Steel  
HCr Coated  
TC Coated  
CC Coated

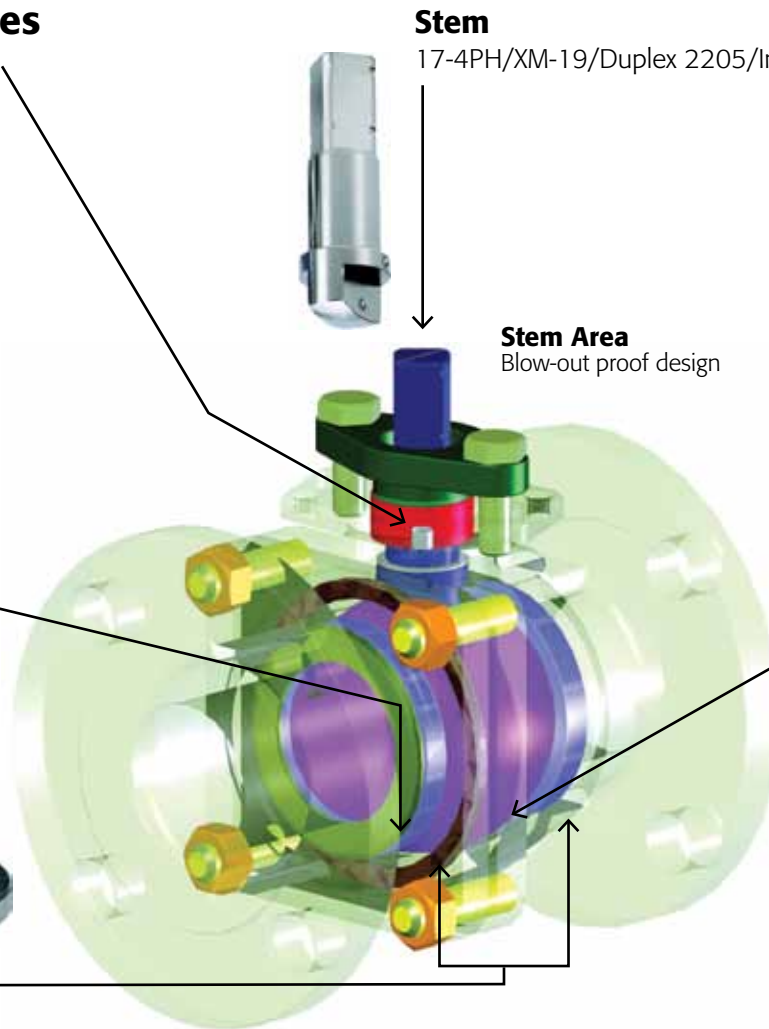

## Uni-directional (Std.)

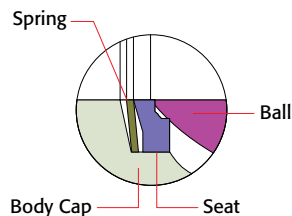

### Seat Area (Upstream Side)

Seat spring provides flexibility under piping stress and thermal expansion, thereby stabilizing operation

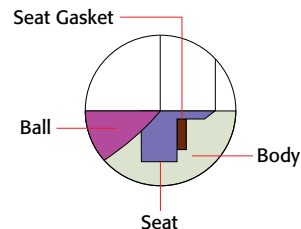

### Seat Area (Downstream Side)

Seat gasket is press-fit into the body, providing stability within wide temperature ranges

## Bi-directional

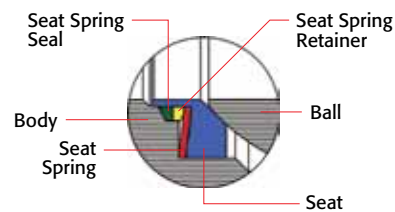

### Seat Area A

Seat spring seal design prevents leakage. Seat spring provides flexibility to piping stress and thermal expansion for stabilizing operation

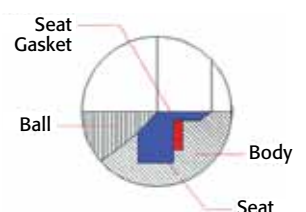

### Seat Area B

Seat gasket is press-fit into the body and provides stability for a wide range of temperatures

# M Series

## Floating Metal Seat Ball Valve

### Applicable Standards

- Body Material: Standard in WCB, CF8, CF8M  
Special material is available based on application
- Nominal Size: 1/2" to 8"
- Available in ANSI 150/300/600LB
- End Connections: Raised face flange
- Temperature Range: -20°F to 1050°F
- Face to Face Dimensions: ANSI B16.10
- Flange Dimensions: ANSI B16.5
- Body Pressure Testing: ANSI B16.34/API 598
- Seat Leakage Testing: ANSI B16.104/FC170-2 Class V
- Casting: MSS SP-61/MSS-SP-25/MSS-SP-55

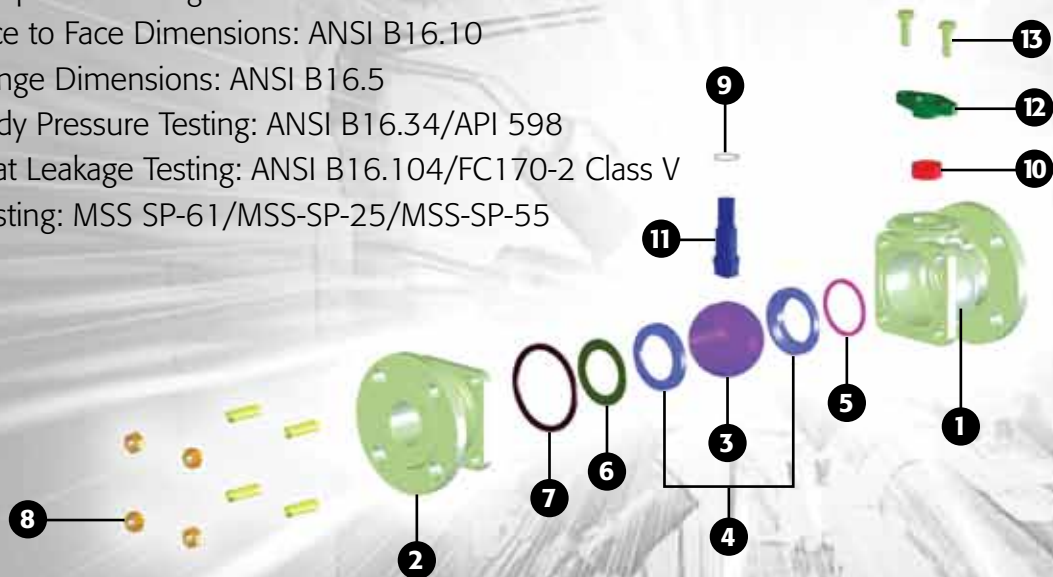

### Technical Specifications

#### MATERIAL

NO.	TEMPERATURE	STELLITE SEAT			TUNGSTEN CARBIDE SEAT		
		-20°F - 660°F			-20°F - 800°F	-20°F - 930°F	
1	Body	WCB	CF8	CF8M	WCB	CF8	CF8M
2	Cap	WCB	CF8	CF8M	WCB	CF8	CF8M
3	Ball	CF8/CF8M + HCr			CF8/CF8M + TC		
4	Seat	SUS304/SUS316 + Stellite			SUS304/SUS316 + TC		
5	Seat Gasket	Graphite					
6	Seat Spring	Inconel X750					
7	Body Gasket	SUS316 + Graphite					
8	Joint Bolt & Nut	B7 & 2H	B8 & 8		B7 & 2H	B8 & 8	
9	Thrust Washer	Stainless Steel					
10	Gland Packing	SUS316 + Graphite					
11	Stem	17-4PH/XM-19/Duplex 2205/Inconel 718			XM-19/Duplex 2205/Inconel 718		
12	Gland	SUS304					
13	Gland Bolt	SUS304					

**NOTE**

HCr - Hard Chrome Plated

TC - Tungsten Carbide Coated

CC - Chrome Carbide Coated Available for Higher Temperature (1050°F)

Above materials may vary with different usage conditions

Stem: 17-4PH SS use below 750°F

Duplex 2205 use below 570°F

Inconel 718 and XM-19 use up to 1100°F

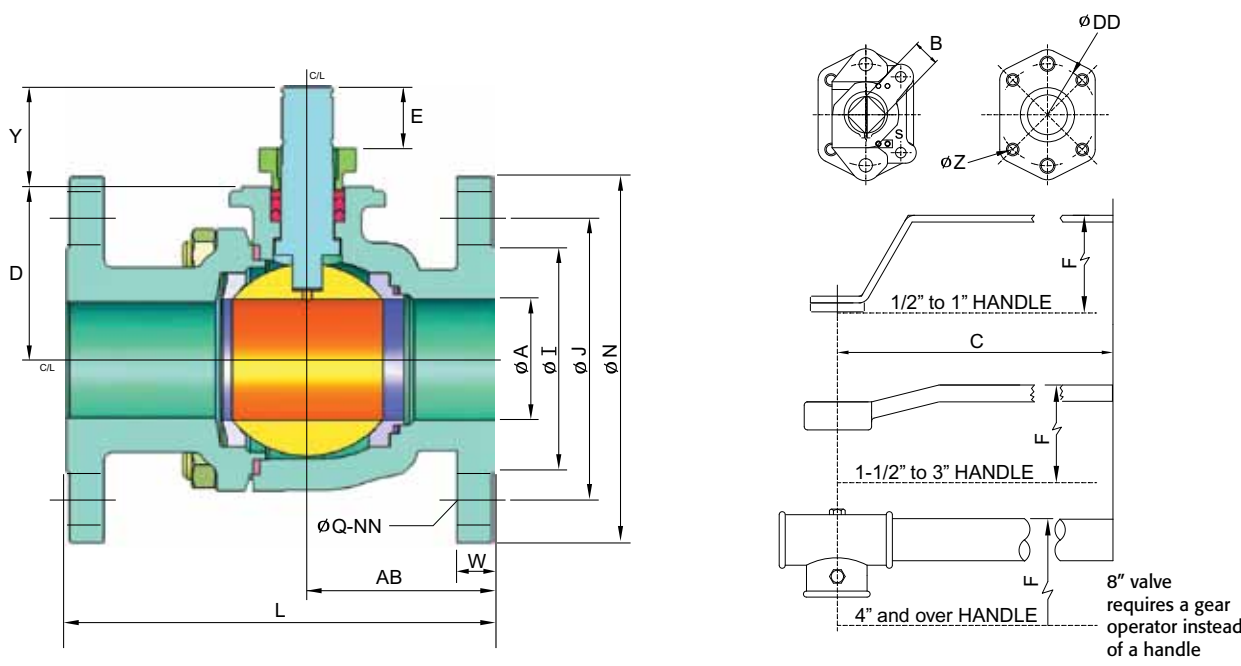

**Dimensions (IN) MU-F1 150#**

SIZE	A	B	C	D	E	F	I	J	L	N	Q	W	Y	Z	AB	DD	NN	ISO 5211	LBS
1/2"	0.59	0.39	5.12	1.48	0.55	2.48	1.38	2.38	4.25	3.74	0.63	0.44	0.98	M5	1.69	1.654	4	F04	4
3/4"	0.79	0.39	5.12	1.59	0.55	2.68	1.69	2.76	4.61	3.86	0.63	0.44	0.98	M5	1.81	1.654	4	F04	5
1"	0.98	0.47	6.30	1.87	0.55	2.99	2.01	3.13	5.00	4.25	0.63	0.44	1.20	M6	2.09	1.969	4	F05	7
1 1/2"	1.50	0.67	8.82	2.56	0.75	3.46	2.87	3.88	6.50	5.00	0.63	0.56	1.65	M8	2.83	2.756	4	F07	14
2"	1.97	0.67	8.82	2.83	0.75	3.70	3.62	4.74	7.01	5.98	0.75	0.63	1.65	M8	3.11	2.756	4	F07	20
2 1/2"	2.56	0.79	12.76	3.58	0.75	4.53	4.13	5.49	7.48	7.01	0.75	0.69	1.83	M8	3.35	2.756	4	F07	29
3"	2.99	0.79	12.76	3.92	0.75	4.72	5.00	6.00	7.99	7.48	0.75	0.75	1.83	M8	3.82	2.756	4	F07	39
4"	3.94	1.06	15.75	4.80	1.02	7.68	6.18	7.50	9.02	8.27	0.75	0.94	2.11	M10	4.45	4.016	8	F10	62
6"	5.91	1.26	21.65	6.61	1.18	9.45	8.50	9.51	15.51	10.98	0.87	1.00	2.44	M12	5.91	4.921	8	F10	140
8"	7.87	1.38	N/A	8.68	1.38	11.81	10.63	11.75	17.99	13.50	0.87	1.13	2.80	M16	8.31	5.512	8	F14	285

**Dimensions (IN) MU-F3 300#**

SIZE	A	B	C	D	E	F	I	J	L	N	Q	W	Y	Z	AB	DD	NN	ISO 5211	LBS
1/2"	0.59	0.39	5.12	1.48	0.55	2.48	1.38	2.62	5.51	3.74	0.63	0.56	0.98	M5	2.32	1.654	4	F04	6
3/4"	0.79	0.39	5.12	1.59	0.55	2.68	1.69	3.25	5.98	4.61	0.75	0.63	0.98	M5	2.64	1.654	4	F04	8
1"	0.98	0.47	6.30	1.87	0.55	2.99	2.01	3.50	6.50	4.88	0.75	0.69	1.20	M6	2.83	1.969	4	F05	11
1 1/2"	1.50	0.67	8.82	2.56	0.75	3.46	2.87	4.51	7.48	6.14	0.87	0.81	1.65	M8	3.23	2.756	4	F07	22
2"	1.97	0.67	8.82	2.83	0.75	3.70	3.62	5.00	8.50	6.50	0.75	0.88	1.65	M8	3.78	2.756	8	F07	27
2 1/2"	2.56	0.79	12.76	3.58	0.75	4.53	4.13	5.87	9.49	7.48	0.87	1.00	1.83	M8	3.90	2.756	8	F07	50
3"	2.99	0.79	12.76	3.92	0.75	4.72	5.00	6.61	11.14	8.27	0.87	1.13	1.83	M8	5.08	2.756	8	F07	70
4"	3.94	1.06	15.75	4.80	1.02	7.68	6.18	7.87	12.01	10.00	0.87	1.25	2.11	M10	5.43	4.016	8	F10	105
6"	5.91	1.26	21.65	6.61	1.18	9.45	8.50	10.63	15.87	12.52	0.87	1.44	2.44	M12	6.69	4.921	12	F12	220
8"	7.87	1.38	N/A	8.68	1.38	11.81	10.63	13.00	19.76	15.00	0.98	1.63	2.80	M16	8.90	5.512	12	F14	380

**Dimensions (IN) MU-F6 600#**

SIZE	A	B	C	D	E	F	I	J	L	N	Q	W	Y	Z	AB	DD	NN	ISO 5211	LBS
1/2"	0.59	0.39	5.12	1.48	0.55	2.48	1.38	2.62	6.50	3.74	0.63	0.82	0.98	M5	2.28	1.654	4	F04	6
3/4"	0.79	0.39	5.12	1.59	0.55	2.68	1.69	3.25	7.48	4.61	0.75	0.88	0.98	M5	2.76	1.654	4	F04	9
1"	0.98	0.47	6.30	1.87	0.55	2.99	2.01	3.50	8.50	4.88	0.75	0.94	1.20	M6	3.03	1.969	4	F05	13
1 1/2"	1.50	0.67	8.82	2.56	0.75	4.72	2.87	4.51	9.49	6.14	0.87	1.13	1.65	M8	4.25	2.756	4	F07	26
2"	1.97	0.67	8.82	3.23	0.75	5.51	3.62	5.00	11.50	6.50	0.75	1.25	1.65	M8	5.28	2.756	8	F07	40
3"	2.99	0.87	12.76	4.51	1.10	7.09	5.00	6.61	14.02	8.27	0.87	1.50	1.83	M8	6.50	2.756	8	F07	80
4"	3.94	1.06	21.65	5.28	1.30	9.45	6.18	8.50	17.01	10.75	0.98	1.75	2.09	M10	8.15	4.016	8	F10	150

Due to continuous product improvements, we reserve the right to modify or change design without incurring any liability to furnish or install such modifications or changes on products previously or subsequently sold.

# M Series

## Floating Metal Seat Ball Valve

### Temperature & Pressure Curve

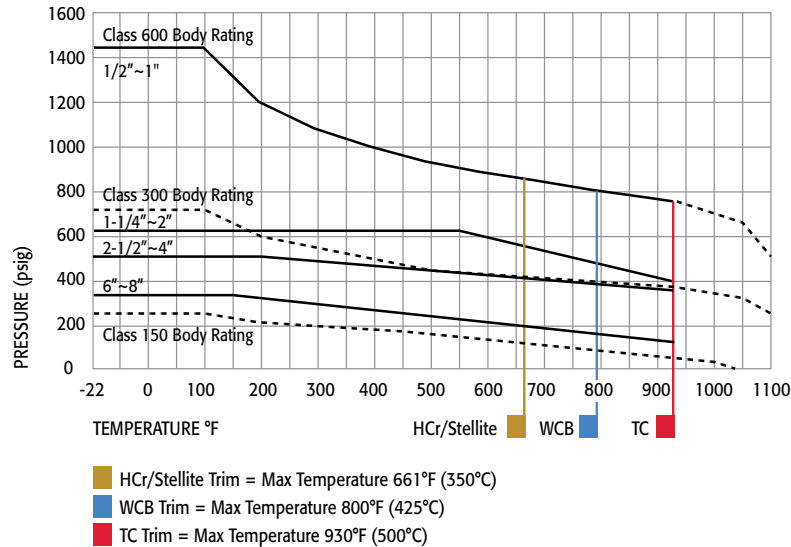

### M Series Metal Seat Torque Table

#### ► 316 HCr/Stellite Trim, Unidirectional (Bi-Directional torque: add 15% to below torques)

	Torques in In-Lbs @ PSIG													
	150	225	300	350	425	500	575	650	725	870	1015	1160	1300	1450
1/2"	90	105	110	110	110	115	120	130	140	165	175	185	210	230
3/4"	130	140	140	150	160	165	190	210	240	265	310	360	405	450
1"	150	170	210	220	235	255	280	310	350	420	475	535	575	635
1-1/2"	415	510	565	600	655	715	785	850	925					
2"	490	715	900	990	1100	1280	1440	1600	1770					
3"	1450	1650	2010	2500	2950	3400								
4"	2600	3250	3950	5215	6255	7290								
6"	3700	9250	11,900	14,500										
8"	12200	15,470	21,575	27,700										

#### ► 316/TC Trim, Unidirectional (Bi-Directional torque: add 15% to below torques)

	Torques in In-Lbs @ PSIG													
	150	225	300	350	425	500	575	650	725	870	1015	1160	1300	1450
1/2"	105	115	140	150	160	185	200	210	215	245	265	290	325	345
3/4"	195	225	290	305	335	360	400	440	520	590	650	700	750	772
1"	260	290	345	390	450	530	550	565	600	690	750	810	865	900
1-1/2"	670	900	1115	1200	1350	1500	1660	1820	1980					
2"	865	1090	1500	1725	1950	2210	2475	2750	3005					
3"	2050	2250	2715	3290	3780	4275								
4"	3150	4227	5300	6360	7400	8450								
6"	4460	11,160	14,350	17,650										
8"	14600	18,555	25,880	33,215										

- Notes:**
- 1) Torques include 30% safety factor tested by warm, clean water.
  - 2) Additional safety factors should be added for high temperature, viscous fluid, powders, steam and slurries.
  - 3) Torques are based on valve being installed in suggested direction.
  - 4) Contact Factory for torques for Bi-directional flow and Tungsten Carbide Trim Valves.

## Manual Ball Valve Part Number Matrix

<p><b>1</b>     <b>Fire Safe Designation</b>  F     Fire Safe Tested</p> <p><b>2</b>     <b>Valve Series</b>  MU    Metal Seat Uni-directional Shutoff, Floating Ball  MB    Metal Seat Bi-directional Shutoff, Floating Ball</p> <p><b>3</b>     <b>Body Material</b>  Blank No Designation = Stainless Steel Body and Trim.  CF8M-316SS (-450° F to 1100° F)  C     Carbon Steel Body, A216 Gr WCB (-20° F to 800° F)  L     Low Carbon 316 Stainless Steel, CF3M-316L ( to 800° F)  7     CG8M 317  D     CD3MN Duplex SS  5     LCB, A352 (-50° F to 650° F)  8     LCC, A352 (-50° F to 650° F)  6     WC6, A217 (-20° F to 1100° F)  9     WC9, A 217 (-20° to 1100° F)</p> <p><b>4</b>     <b>End Connection</b>  F1    150# Flanged Ends  F3    300# Flanged Ends  F6    600# Flanged Ends  FR    600# RTJ Flanged Ends</p> <p><b>5</b>     <b>Valve Size</b>  0050 1/2"  0075 3/4"  0100 1"  0150 1-1/2"  0200 2"  0250 2-1/2"  0300 3"  0400 4"  0600 6"  0800 8"</p>	<p><b>6</b>     <b>Seat, Lining &amp; Trim Materials</b>  2     Tungsten Carbide Coated 316SS Seats &amp; Ball  3     HCR Coated Ball/Stellite Inlay Seat  4     Chrome Carbide Coated 316SS Seat &amp; Ball</p> <p><b>7</b>     <b>Special Designations</b>  X     No Specials  G     Gear Operator</p> <p><b>8</b>     <b>Additional Specials</b>  X     No Specials  O     Oxygen Cleaned  Z     Special End Configuration  V     Vented Ball</p> <p><b>9</b>     <b>Special Stem Designation</b>  Blank No Designation = Standard Stem  A     17-4PH Stem  B     XM-19 (Nitronic 50) Stem  C     Duplex 2205 Stem  D     Inconel 718 Stem</p>
---	---



### How To Order

<b>1</b>	-	<b>2</b>	-	<b>3</b>	-	<b>4</b>	-	<b>5</b>	-	<b>678</b>	-	<b>9</b>
↓		↓		↓		↓		↓		↓ ↓ ↓		↓
<b>F</b>	-	<b>MU</b>	-	<b>C</b>	-	<b>F3</b>	-	<b>0150</b>	-	<b>3XX</b>	-	<b>A</b>



## A-T Controls, Inc.

11363 Deerfield Rd.  
Cincinnati, Ohio 45242  
513-530-5175 · 247-5465  
FAX 513-247-5462  
e-mail: sales@a-tcontrols.com

See our website!  
<http://www.a-tcontrols.com>

20120207-FMU



6D-0539



ISO 9001



0575