

Cv factors for valve sizing

Class 150 & Class 300

Size	2-Way	3-Way A, AX, C pos.	3-Way D pos. 0° & 180°	3-Way D pos. 90°	4-Way	5-Way
1/2	9	7	4	5	4	6
3/4	9	7	4	5	6	6
1	43	20	11	17	15	27
1 1/2	89	40	21	37	30	42
2	172	70	40	47	54	69
3	294	100	54	87	74	120
4	548	175	94	159	150	200
6	1,075	350	210	255	340	390
8	1,591	475	360	450	455	575
10	2,159	650	450	750	610	785
12	3,200	965	650	1,000	900	1,160

Class 150

Size	2-Way
14	3,200
16	5,280
18	5,600
20	5,900
24	11,000

Class 300

Size	2-Way
14x12x14	3,200
14x16x14	5,280
16	5,600
18	5,900
20	11,000

Operating torques (Inch-Pounds)

Figures are for 2-Way valves with PTFE sleeves. Consult factory for torque adjustment factors for other sleeve materials.

Class 150 & 300

Size	Break Torque	Seating Torque	Running Torque
1/2	140	80	70
3/4	140	80	70
1	400	250	200
1 1/2	800	500	400
2	1,100	650	550
3	1,200	700	600
4	2,400	1,450	1,200
6	5,000	3,000	2,500
8	7,800	4,700	3,900
10	14,400	8,600	7,200
12	21,000	12,600	10,500

Class 150

Size	Break Torque	Seating Torque	Running Torque
14	21,000	12,600	10,500
16	36,000	21,000	18,000
18	36,000	21,000	18,000
20	36,000	21,000	18,000
24	100,000	60,000	50,000

Class 300

Size	Break Torque	Seating Torque	Running Torque
14x12x14	21,000	12,600	10,500
14x16x14	36,000	21,000	18,000
16	36,000	21,000	18,000
18	36,000	21,000	18,000
20	100,000	60,000	50,000

Screwed end dimensions

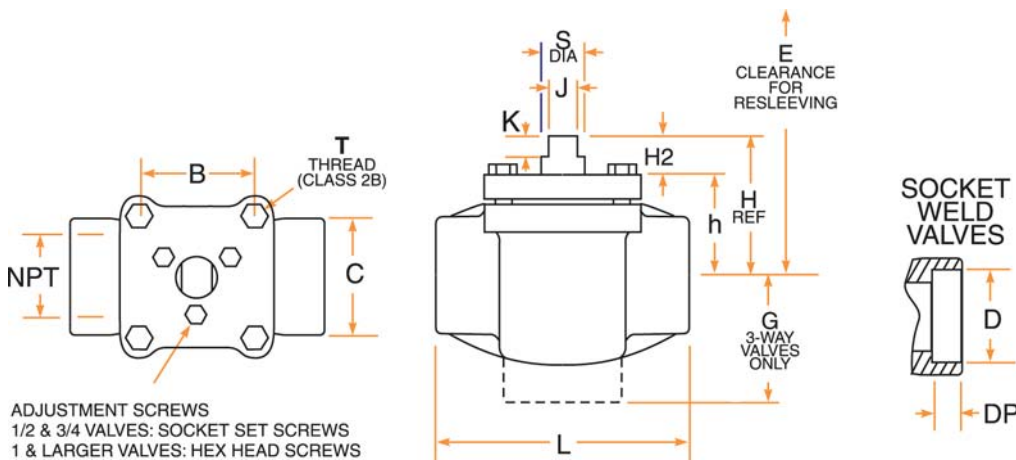

Socket Weld

Size	D	DP
1/2	.860	.38
3/4	1.070	.50
1	1.335	.50
1 1/2	1.920	.50
2	2.411	.63

Screwed End / Class 150 / 2-Way - Figure No. 066 & 3-Way Figure No. 036 Class 300 / 2-Way - Figure No. 0366 & 3-Way Figure No. 0336

Size	L	H	h	H2	B	C	S	J	K	T	E	Weight 2-Way	G 3-Way	Weight 3-Way
1/2	3.25	1.92	1.06	.86	1.43	1.68	.50	.250	.66	5/16-18	6.00	1.5	1.69	1.75
3/4	3.25	1.92	1.06	.86	1.43	1.68	.50	.250	.66	5/16-18	6.00	1.5	1.80	1.75
1	4.63	2.50	1.66	.86	1.90	2.21	.63	.438	.32	3/8-16	7.00	4	2.38	5
1 1/2	5.50	3.06	2.09	.97	2.33	2.33	.88	.563	.44	3/8-16	8.00	10	2.88	11
2	6.50	3.56	2.56	1.00	3.02	3.02	1.13	.750	.53	7/16-14	9.13	14	3.38	16

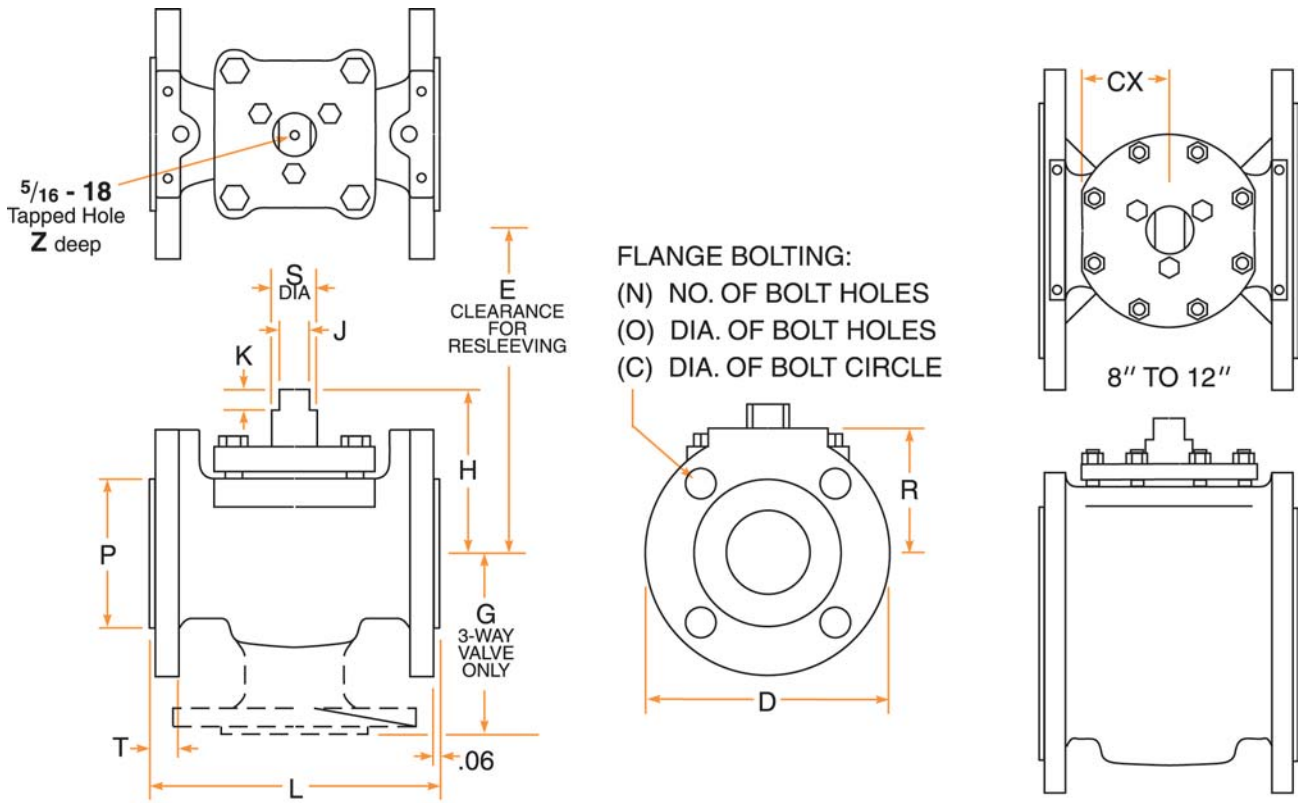

Dimensions

Flanged End / Class 150 / 2-Way - Figure No. 067 & 3-Way Figure No. 037

Size	L	H	D	T	P	R	N	O	C	S	J	K	E	Z	CX	Weight 2-Way	G 3-Way	Weight 3-Way
1/2	4.25	1.92	3.50	.38	1.38	1.75	4	.63	2.38	.50	.250	.66	6.00	-	1.09	2.8	2.75	3.8
3/4	4.63	1.92	3.88	.41	1.69	1.94	4	.63	2.75	.50	.250	.66	6.00	-	1.09	3.3	2.88	4.5
1	5.00	2.50	4.25	.44	2.00	2.13	4	.63	3.13	.63	.438	.32	7.00	.53	1.38	6.5	3.50	9
1 1/2	6.50	3.06	5.00	.56	2.88	2.50	4	.63	3.88	.88	.563	.44	8.00	.59	1.56	13	4.13	17
2	7.00	3.56	6.00	.63	3.63	3.00	4	.75	4.75	1.13	.750	.53	9.13	.78	2.00	20	4.50	26
2 1/2†	8.00	4.13	7.50	.75	4.13	3.75	4	.75	5.50	1.13	.750	.53	10.13	.78	2.00	31	5.13	42
3	8.00	4.13	7.50	.75	5.00	3.75	4	.75	6.00	1.13	.750	.53	10.13	.78	2.00	31	5.13	42
4	9.00	5.22	9.00	.94	6.19	4.63	8	.75	7.50	1.25	.875	.78	22.00	.90	2.50	54	6.00	69
6	10.50	7.35	11.00	1.00	8.50	5.50	8	.88	9.50	2.00	1.398	1.00	25.00	-	3.06	95	7.50	119
8	11.50	9.32	13.50	1.13	10.63	6.75	8	.88*	11.75	2.00	1.398	1.00	28.00	-	4.12	175	9.00	214
10	13.00	10.81	16.00	1.19	12.75	8.00	12	1.00*	14.25	2.50	1.673	1.00	29.00	-	4.50	260	11.00	331
12	14.00	11.81	19.00	1.25	15.00	9.50	12	1.00*	17.00	3.00	1.968	1.00	35.00	-	5.31	355	-	-
14	15.00	11.75	21.00	1.38	16.25	10.50	12	1.13*	18.75	2.97	1.968	.995	N/A	-	5.31	430	-	-
16	30.00	14.96	23.50	2.12	18.50	11.50	16	1.13	21.25	3.94	2.00	1.575	N/A	-	N/A	925	-	-
18	33.00	14.96	25.50	2.25	21.00	12.75	16	1.25	22.75	3.94	2.00	1.575	N/A	-	N/A	1,005	-	-
20	36.00	14.96	27.50	2.38	23.00	14.00	20	1.25	25.00	3.937	2.00	1.575	N/A	-	N/A	1,200	-	-
24	39.00	20.48	32.00	2.50	27.25	16.13	20	1.38*	29.50	6.00	4.00	2.000	N/A	-	N/A	2,500	-	-

* On 8" valves, the two top holes in the flange are tapped for 3/4-10UNC-2B threads.
 On 10" and 12" valves, the two top holes in the flange are tapped for 7/8-9UNC-2B threads.
 On 14" valves, the two top holes in the flange are tapped for 1-8UNC-2B threads.
 On 24" valves, the top six holes in the flange are tapped for 1 1/4-8UNC-2B threads.
 † 2 1/2" valves are machined from 3" castings, but the flanges are machined to 2 1/2" dimensions.

Dimensions are in inches. Weights are in pounds.

Flanged End / Class 300 / 2-Way - Figure No. 0367 & 3-Way Figure No. 0337

Size	L	H	D	T	P	R	N	O	C	S	J	K	E	Z	CX	Weight 2-Way	G 3-Way	Weight 3-Way
1/2	5.50	1.92	3.75	.56	1.38	1.88	4	.63	2.63	.50	.250	.66	6.00	-	1.09	6	2.88	8
3/4	6.00	1.92	4.63	.63	1.69	2.31	4	.75	3.25	.50	.250	.66	6.00	-	1.09	9	3.00	12
1	6.50	2.50	4.88	.69	2.00	2.44	4	.75	3.50	.63	.438	.32	7.00	.53	1.38	11	3.75	15
1 1/2	7.50	3.06	6.13	.81	2.88	3.06	4	.88	4.50	.88	.563	.44	8.00	.59	1.56	21	4.38	29
2	8.50	3.56	6.50	.88	3.63	3.25	8	.75	5.00	1.13	.750	.53	9.13	.78	2.00	28	4.75	37
2 1/2†	11.13	4.13	8.25	1.13	4.13	4.13	8	.88	5.88	1.13	.750	.53	10.13	.78	2.00	38	5.56	53
3	11.13	4.13	8.25	1.13	5.00	4.13	8	.88	6.63	1.13	.750	.53	10.13	.78	2.00	38	5.56	53
4	12.00	5.22	10.00	1.25	6.19	5.13	8	.88	7.88	1.25	.875	.78	22.00	.90	2.50	80	6.75	105
6	15.88	7.35	12.50	1.44	8.50	6.25	12	.88	10.63	2.00	1.398	1.00	25.00	-	3.06	165	8.50	207
8	16.50	9.32	15.00	1.63	10.63	7.50	12	1.00	13.00	2.00	1.398	1.00	28.00	-	4.12	267	10.00	334
10	18.00	10.81	17.50	1.88	12.75	8.75	16	1.13	15.25	2.50	1.673	1.00	29.00	-	4.50	395	12.00	470
12	19.75	11.81	20.50	2.00	15.00	10.25	16	1.25	17.75	3.00	1.968	1.00	35.00	-	5.31	540	-	-
14	30.00	14.96	23.00	2.12	16.25	11.50	20	1.25*	20.25	3.937	2.00	1.575	N/A	-	N/A	925	-	-
16	33.00	14.96	25.50	2.25	18.50	12.75	20	1.38	22.50	3.937	2.00	1.575	N/A	-	N/A	1,005	-	-
18	36.00	14.96	28.00	2.38	21.00	14.00	24	1.38	24.75	3.937	2.00	1.575	N/A	-	N/A	1,200	-	-
20	39.00	20.48	32.00	2.50	23.00	16.13	16	1.38	27.00	6.00	4.00	2.00	N/A	-	N/A	2,500	-	-

* On 14" valves, the two top holes in the flanges are tapped for 1-8UNC-2B threads.

† 2 1/2" valves are machined from 3" castings, but the flanges are machined to 2 1/2" dimensions.

Dimensions are in inches. Weights are in pounds.

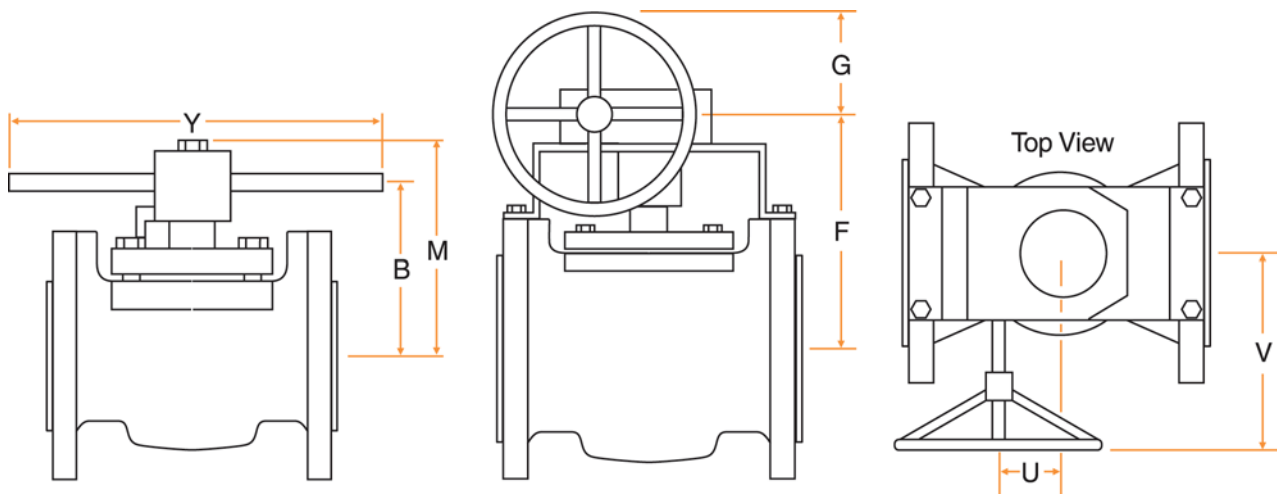

Wrench & Enclosed Gear Operator Dimensions

These operator dimensions apply to all flange types and all multiport valves.

Size	M	B	Y
1/2	-	4.00	6.38
3/4	-	4.00	6.38
1	3.81	2.88	8.75
1 1/2	4.56	3.63	12.50
2	5.13	4.00	18.00
2 1/2	5.69	4.63	24.00
3	5.69	4.63	24.00
4	7.06	5.75	30.00

Size	F	G	U	V
4	8.75	6.00	2.06	8.00
6	11.50	9.00	2.62	10.38
8	13.50	9.00	2.62	10.38
10	15.25	12.00	3.53	12.31
12	16.25	15.00	4.88	15.88
14	21.66	15.00	5.38	16.90
16	21.66	12.00	5.12	17.66
18	21.66	12.00	5.12	17.66
20	32.92	15.75	16.97	24.00
24	32.92	15.75	16.97	24.00